

EE 201

Function / Arbitrary Waveform Generator and Oscilloscope Tutorial

This is a programmed learning instruction manual. It is written for the Agilent DSO3202A Digital Storage Oscilloscope. The prerequisite for utilizing this guide is a general physics background. No prior knowledge of or experience with oscilloscopes is needed. As you do each step, it is suggested that you place a check mark by it. Record comments and observations in your notebook. Your completed notebook is your personalized instruction manual for this instrument. Save it for future use - virtually all of our laboratories are equipped with an oscilloscope.

We use programmed learning for this because it allows you to set your own rate of progress. Act accordingly. Repeat steps if necessary. Go back if necessary. Get help if necessary.

Record important information in your lab notebook. Make a brief statement about each step, (Roman numeral steps), in your notebook.

LABORATORY WORK

I. Introduction

- A. Study the front panel of the oscilloscope at your work station; in particular, note the location of:
 1. The power switch (power on/off)
 2. The VERTICAL or y-axis controls (dials with yellow/green center)
 3. The HORIZONTAL or x-axis controls (top left dials)
 4. The TRIGGER controls (green box)
 5. The following buttons or keys:
 - Measure
 - Acquire
 - Display
 - Auto-scale
 - Menu ON/OFF and 5 menu keys below
 6. The calibrating signal terminal
 7. The Model number
- B. Perform the following steps to familiarize yourself with the oscilloscope and the function generator.
 1. Connect a black BNC-BNC cable from the function generator's **OUTPUT** connector to the oscilloscope's channel 1 input connector.
 2. Turn on the oscilloscope and wait until the grid appears.

3. Turn on the function generator. Press the output button located to the left of the Sync port. This will cause the function generator to output a wave.
4. On the function generator, change the frequency of the wave to 10 kHz by doing the following. Press the blue button under Freq/Period. Make sure Freq (and not Period) is highlighted. You may need to push the blue button a second time. Using the dial and the left/right position buttons located above the output port, increased the frequency to 10 kHz. Then change the amplitude of the wave to 500mV in the same manner by pushing the blue button under the word Ampl/HiLevel. Make sure Ampl is selected.
5. Press the **Auto-scale** button on the oscilloscope. A sine wave should be seen. Look at the **Status Line** below the sine wave. It should indicate a vertical sensitivity of 200 mV (per div) and a sweep rate of 50 μ s (per div). (You may see a different value for the vertical sensitivity. This will be accounted for in Step 7.)
6. Rotate the oscilloscope's **Horizontal** knob (which controls **Time/div**), located in the upper-left corner, both directions noting the change in both the tracing and the **Status Line**. Return the knob to the 50 μ s setting. Now try pressing the knob like a button to see the **Zoom** feature. Press the knob again to return to normal viewing mode.
7. Press the oscilloscope's **1** button. Press, in turn, each of the first four buttons to the right of the tracing, returning each to its original indication. (If your Probe value is not already, set it to 1x.) Note the effects.

The purpose of the Coupling option is to enable the oscilloscope user to block the DC component of a signal or to permit the DC component to be applied to the deflection plates. The logic behind this option will be brought out later in the exercise. The GND position of the Coupling option grounds the input to the vertical amplifier channel without grounding the applied signal. The essential features of the Coupling option are depicted in Figure 1.

8. Rotate the oscilloscope's channel 1 **Vertical** knob (which controls **Volts/Div**) both directions noting the change in both the tracing and the Status Line. Return the knob to the 200 mV setting.
9. Rotate the channel 1 **Position** knob (the smaller colored knob located under the **1** button) both directions noting the change in both the tracing and the highlighted indication below the tracing. Return to Position (1) = 0 V.

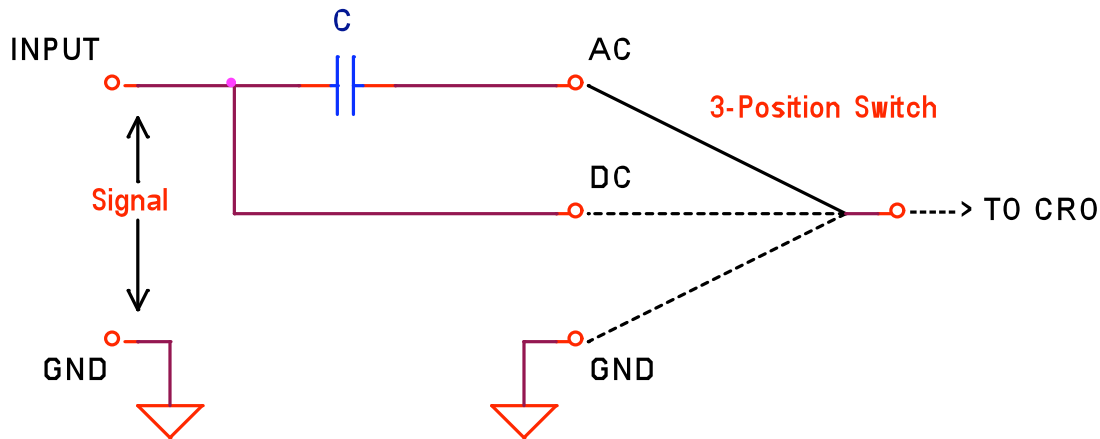

Figure 1. Input coupling selection

10. Rotate the **Delay** knob (located next to the **Main/Delayed** button) both directions noting the change in both the tracing and the **Status Line**. Return the knob to the 0s setting. Note that the horizontal and vertical positioning controls are independent of each other.
11. Rotate the oscilloscope's trigger **Level** knob both directions noting the change in both the tracing and the highlighted indication below the tracing. Return to Trigger level (1) = 0 V.
12. On the function generator press, in turn, the square, ramp, pulse, noise, and arb buttons. Note the change in both the tracing and in the function generator's display. Return to sine wave.
13. Press the blue button under Freq/Period and rotate the large knob in both directions. Make sure Freq (and not Period) is highlighted. Note the change in both the tracing and in the function generator's display. Return to 10 kHz. Hit the blue button again to select Period. Turn the knob and view the changes. Return the Period to 100 μ s.
14. Press the blue button under Ampl/HiLevel and rotate the large knob in both directions. Make sure Ampl (and not HiLevel) is highlighted. Note the change in both the tracing and in the function generator's display. Return to 500 mVpp. Hit the blue button again to select HiLevel. Turn the knob and view the changes. Return the value to 250 mV.
15. On the function generator:
 - Press the **Arb** button.
 - Press the blue button under Select Wform.
 - Press the blue button under Built-In.
 - Press the blue button under **CARDIAC**.

The waveform is, hopefully, similar to the electrical signal produced by your beating heart (electrocardiogram - ECG). Finally press the sine wave button.

II. The Oscilloscope as an AC Voltmeter--The Sweep System

- A. Now we will use the oscilloscope to measure time-varying voltages. Periodic voltages will be used; these signals are repeated at regular intervals. They may be developed by either oscillators or function generators. Oscillators develop voltages that vary sinusoidally with respect to time. Function generators develop sinusoids, square waves, triangular waves, ramps (sawtooths), and other waveforms.

The H-P 33120A function generator is equipped with

1. A Power switch
2. Function buttons to control:
 - Type of waveform (wave shape)
 - Frequency of waveform (Hz, kHz, MHz)
 - Amplitude of waveform (mV or V)
 - Many other features and operating modes
3. A multipurpose display which shows the waveform's parameters
4. A vernier knob for adjusting (usually) frequency and voltage
5. Signal output and sync connectors

- B. Set the oscilloscope controls as follows:

Vertical Controls

Channel 1: On, DC Coupling, 2V/DIV

To choose DC Coupling, push **1** and change coupling to DC

Channel 2: On, DC Coupling, 2V/DIV

Horizontal Controls

Press the **Main/Delayed** button

Time Base: **X-Y**

Trigger Controls

Source: 2 (Press **Mode/Coupling**, choose **Source**: CH2)

Sweep: Auto

Slope: positive

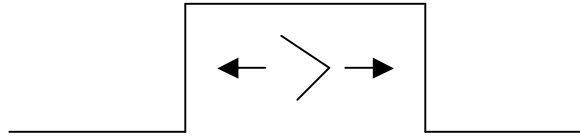

Coupling: DC

To choose DC Coupling, push **Mode/Coupling** and change coupling to DC

- C. Connect the function generator and power supply to the oscilloscope as shown in Figure 2. (Leave the power supply turned off.)

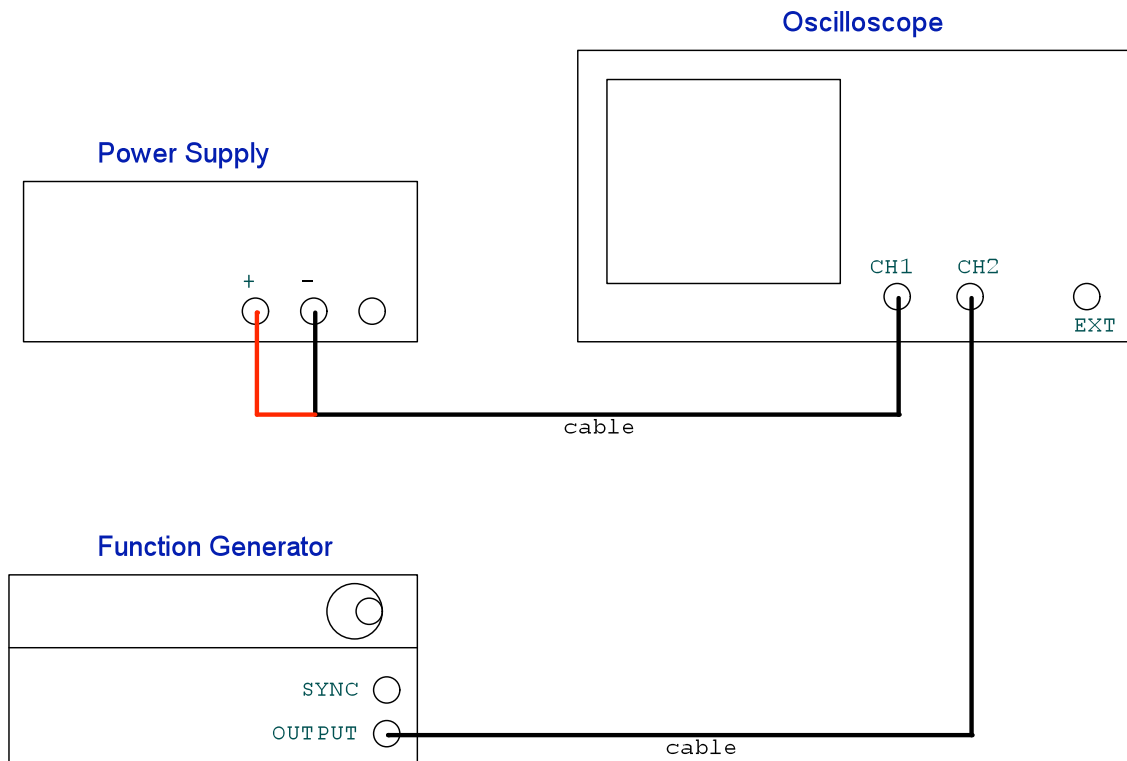

Figure 2. AC Voltage Measurements

- D. Energize the function generator and press these buttons:

Make sure to check the Output Impedance of the function generator. Use the following steps:

Note: This must be done every time the function generator is to be used.

Push Utility → Output Setup → Select High Z → Done

Set the frequency to 0.5 Hz by selecting frequency on the main menu and using the dial.

Adjust the amplitude to 8 V peak-to-peak by selecting Ampl on the main menu and turning the large knob so that the display reads 8.000 VPP. Adjust the horizontal and vertical dials to display the wave appropriately. How many divisions is the spot on the oscilloscope deflected, and what is the peak-to-peak voltage?

Now change the output impedance of the function generator using the same procedure but selecting “Load.” Press done. What effect did this have? Notice the amplitude displayed on the function generator. Now adjust the amplitude back to 8.000 VPP on the function generator. How many divisions is the spot on the oscilloscope deflected, and what is the peak-to-peak voltage? Reduce the output back to 4.000 Vpp and change the output to High Z.

Important Note: The generator must be set to High Z for the output impedance so that the oscilloscopes input impedance is the same as the function generator.

- E. The voltage being applied to the vertical deflection plates is $V_m \sin \omega t$, and in this case V_m is 4 volts. The angular frequency, ω , is equal to $2\pi f$, where $f = 0.5$ Hz. ω is measured in radians/second (rad/s). See Figure 3.

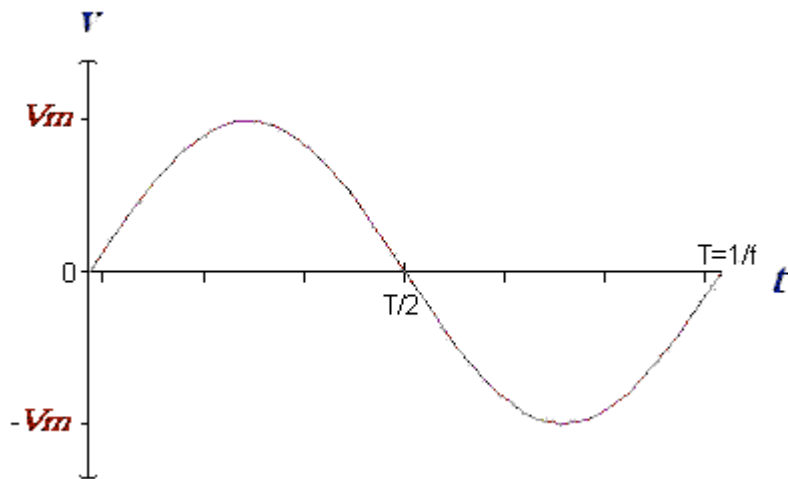

Figure 3. Sinusoidal Voltage

- F. Now back to the spot slowly going up and down. Try to visualize what would happen if, while the spot is moving as it is now, a voltage were applied to the horizontal deflection plates. The resulting display should look just like the graph of Figure 3. Such a display would represent the voltage applied to the

vertical plates as a function of time. Turn on the power supply and adjust the voltage to 0V.

- G. Rotate the voltage adjust knob of the variable DC voltage supply at a uniform rate, and return it to zero. Do this several times, at various rates. Does the display look something like Figure 3?
- H. If we let the total time during which you are rotating the voltage control of the power supply be designated by T_1 seconds, the output voltage you are producing is shown graphically in Figure 4. This is the voltage applied to the horizontal plates. In effect, you have manually “swept” the beam horizontally across the screen with a constant velocity. The time T_1 is called the “sweep time,” and this voltage is the sweep voltage. The amount of time to go 1.0 div is called the “sweep rate.”

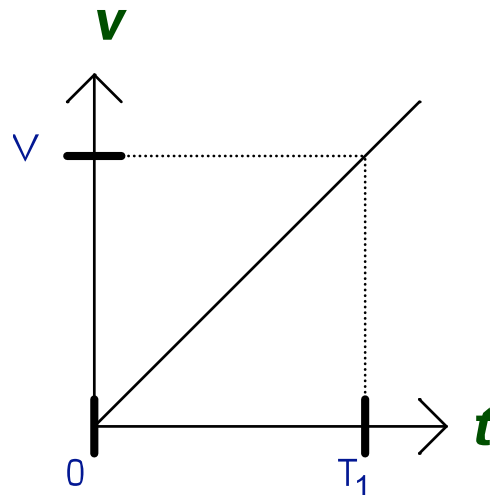

Figure 4. Sweep Voltage

- I. Increase the frequency to 100 Hz. Again rotate the voltage dial. Can you achieve a display similar to Figure 3? Why?
- J. Providing a sweep system in this manual fashion is impractical. When alternating or time-varying voltages are to be measured, a horizontal sweep system is used. This system will now be demonstrated.
- K. Turn off the power supply and disconnect it from the oscilloscope.
- L. Move the function generator output to Channel 1. Return the scope to Y-T mode (**Time Base** under the **Main/Delayed** menu) and turn the **Horizontal** knob to obtain a sweep rate of 2ms/div. You should now have one cycle of a sine waveform displayed on the oscilloscope grid.
- M. Change the frequency to 500 Hz and rotate the **Horizontal** knob until you get one or two complete cycles on the screen. Change the frequency to 10,000

Hz and repeat. Notice how convenient it is to observe a signal of almost any frequency. How many sweep rates are available? What is the shortest sweep time (fastest sweep rate)? What is the longest sweep time (slowest sweep rate)?

- N. Figure 5 shows the repetitive voltage that is applied to the horizontal plates to sweep the electron beam. For obvious reasons, it is commonly called a “sawtooth voltage.” When the sweep rate is 0.5 s/div, then T_2 is 5 seconds. During the interval Δt the electron beam is turned off or “blanked,” so that confusing traces will not occur.

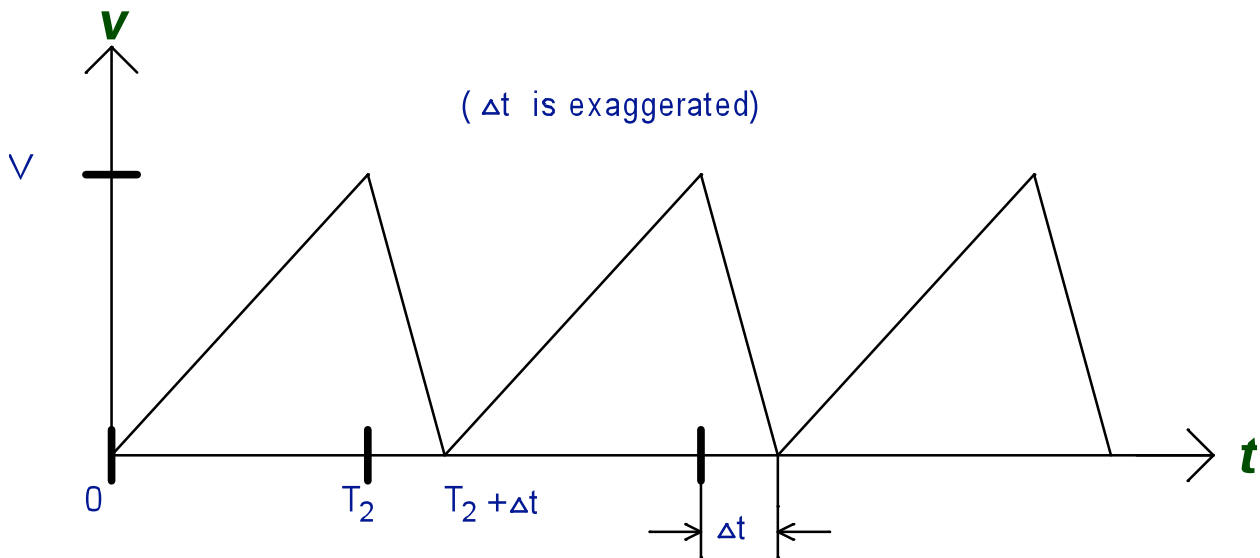

Figure 5. Automatic Sweep Voltage

- O. It is possible to use the oscilloscope to measure frequency. Set the frequency to a value between 1000 and 2000 Hz. From the display, count the number of divisions for one cycle of the sine wave. This distance multiplied by the sweep rate is the period, and the reciprocal of the period is the frequency.

Measured frequency from oscilloscope: _____ Hz
 Frequency according to function generator: _____ Hz

The oscilloscope also has a frequency display mode. Make sure at least a few full periods are displayed and ensure that the top and bottom of the wave are not cut off. Press these buttons:

Measure, then **Time**, then **Frequency**.

Indicated frequency: _____ kHz

The above three values should be reasonably close, within 3%. If they differ, which do you think is more nearly correct? Why?

Rotate the large knob on the function generator to increase the frequency and note the effects on the oscilloscope. To remove the frequency reading, push **Measure** then push the button next to clear.

- P. Set the **Horizontal** control to 50 μs and set the signal source to give you a 10 kHz, 12 volt peak-to-peak square wave. Cycle the Coupling (by pressing **1** and changing the coupling options) through its three settings (DC, AC, GND). Note that at this frequency there is little effect between the DC and AC input coupling modes. When GND is selected, the signal is no longer displayed -- a zero-volt reference line is seen.
- Q. Set the square wave frequency to 20 Hz and the sweep rate to 10 msec/div. Change the **Coupling** back to AC, then to DC. Note that at this frequency, the AC setting introduces a substantial distortion into the picture. Which setting would you use for display of very low frequency signals?

III. Using the Oscilloscope as a DC Voltmeter

- A. Can you use the oscilloscope to measure DC voltage? Sketch what the display of the oscilloscope would look like if you measured 2Vdc with the Volts/div set at 1V.

IV. Signals with AC and DC Components

Now we will investigate the use of AC coupling at the input of the oscilloscope to subtract the DC component of an input signal.

- A. Set the frequency of the function generator to 10 kHz (square wave). Set the amplitude to 2 VPP.
- B. Connect the function generator to channel 1 of the oscilloscope. Press **Auto-scale**.
- C. Adjust the oscilloscope settings:

Channel 1: 2 Volts/Div. DC coupled
Time/Div: 50 μs
- D. A 4-volt dc offset will now be added to the displayed square wave. To do this, select the **Offset** option on the Function Generator. Change the offset to 4 Vdc.
- E. Select AC Coupling for channel 1. The trace should move down 2 divisions. Cycle the input coupling several times between DC and AC. Note that on AC, the average (DC) level of any input signal will be subtracted from the signal before the display is developed. This feature can be used to measure the average value of a signal. **Remember this!**

V. The Dual Trace System

- A. It is often desirable to study, simultaneously, signals at two different points in a circuit. The dual trace system makes this possible. A dual trace amplifier is an amplifier equipped with two signal channels, a switching circuit, and an output amplifier, as shown in Figure 6.

From this block diagram of the dual trace amplifier it can be seen that the signal applied to the oscilloscope deflection plates depends on the operating mode of the switching circuit. The possible combinations are as follows:

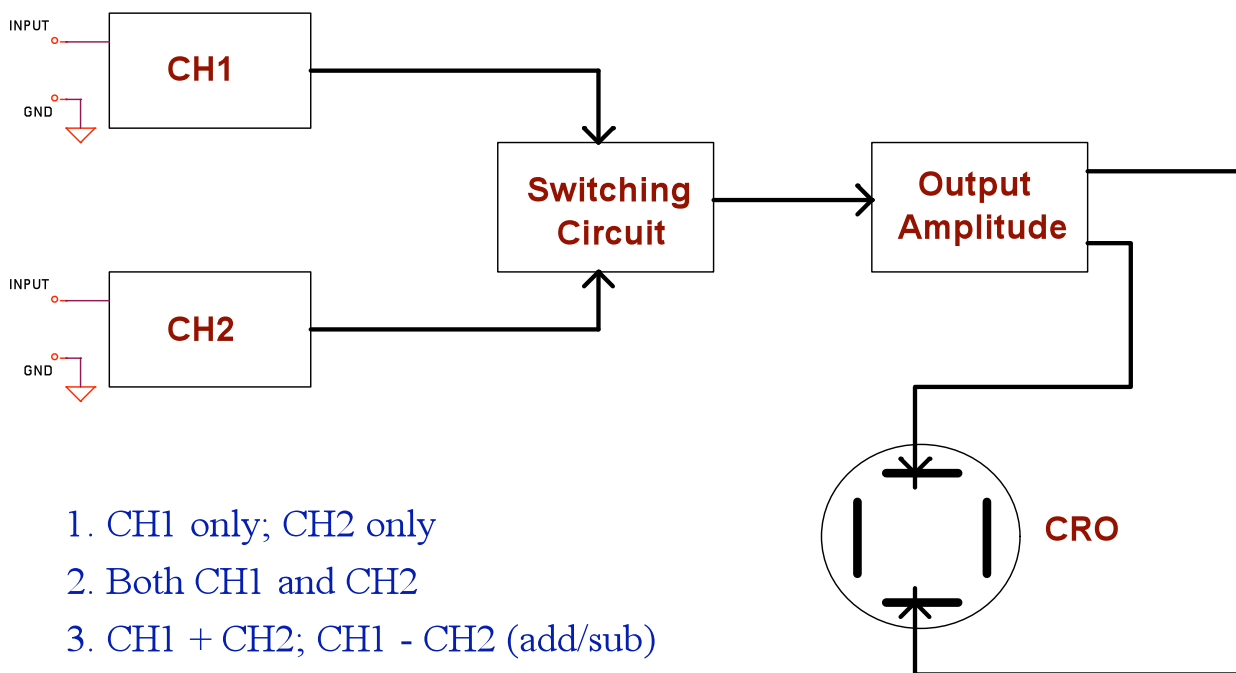

1. CH1 only; CH2 only
2. Both CH1 and CH2
3. CH1 + CH2; CH1 - CH2 (add/sub)

Figure 6. Block Diagram of Dual Trace Amplifier

1. A single signal can be fed to the deflection plates either through Channel 1 or Channel 2.
2. Two signals can be displayed simultaneously by connecting a signal to each channel input and then turning on both channels.
3. The algebraic sum or difference of two signals can be displayed as a single trace by using the **Math** button and selecting either the **1 + 2** or **1 - 2** option (press the **Operate** menu button). Look at the other math options as well.

- B. Set the oscilloscope controls as follows:

Vertical Controls

Ch. 1 and Ch. 2 Volts/Div: 2
Coupling: GND

Horizontal Controls

Time/Div: 1 ms

Trigger Controls(Press **Mode/Coupling**)

Source: 1
Mode: Edge
Slope: positive (up arrow)
Coupling: AC
Level: approximately 50% (Press the **50%** button)
Sweep: Auto

- C. Adjust the **Position** control for channel 1 to position its trace 2 div above the center of the CRT screen. Adjust the **Position** control for channel 2 to position its trace 2 div below the center of the screen.

- D. Turn on the function generator and make sure the output impedance is set to HIGH Z.

Use a frequency of 1 kHz and amplitude of 1 VPP

- E. On the oscilloscope, press **1**, and then change **Coupling** to **DC**. Describe the oscilloscope trace. Now press **2**, and then change **Coupling** to **DC**, and describe the trace. Move the cable from Channel 1 to Channel 2 and describe the trace. Press **Mode/Coupling**, and then change **Source** to **CH 2**, and describe the trace. (You must “trigger” the oscilloscope from a displayed signal to see a stable trace!).

VI. Trigger Controls

Until now, the instructions have directed you to set the trigger controls. This has been done with no explanation so that you could study other oscilloscope features. It is now time to consider the trigger controls in detail. The triggered sweep feature of the modern oscilloscope gives the oscilloscope a lot of versatility.

- A. Set the oscilloscope controls as follows:

Vertical Controls

Channel 1: 2 Volts/Div. On
Coupling: DC
Position (1): 0 V
Channel 2: off

*Horizontal Controls*Time/Div: 50 μ s*Trigger Controls*

Source: 1

Mode: Edge

Slope: positive (up arrow)

Coupling: DC

Level: 0 V

- B. Apply a 5000 Hz sinusoidal signal to channel 1. Adjust its amplitude to 8 volts peak-to-peak.
- C. Rotate the **Trigger Level** control and note its effect. The trigger point is the intersection of the horizontal line and the sine wave at the vertical axis in the center of the screen. The actual trigger voltage is displayed in a shaded box in the bottom left-hand corner of the grid. Note that you cannot obtain an unstable trace as long as the trigger level line is on the waveform.
- D. Change the trigger **Slope** to negative (down arrow). What happens? Return to positive slope triggering.
- E. Change the trigger **Coupling** to **AC** and rotate the **Level** control. Now the shaded box shows a percent indication. Return to **DC** coupling.
- G. Change the trigger **Source** to channel 2. Since you are viewing channel 1 and triggering from channel 2 (which has no signal), a stable trace is lost. Now change the trigger **Source** to **EXT/5**. The trigger system is now looking at the **Ext Trig** (External Trigger) connector for a signal. Attach a BNC-BNC cable from the function generator's **SYNC** connector to the oscilloscope's **Ext Trig** connector. A stable trace is seen. Finally, change the trigger source to **AC Line** button below the grid. The waveform is being triggered at a rate set by the frequency of the ac power system in the building. This frequency is nominally 60 Hz. Adjust the frequency of the function generator to the values listed below and describe the results. You may have to change the **Time/Div** setting. Are all the traces stable?

30 Hz: _____

60 Hz: _____

90 Hz: _____

120 Hz: _____

Remove the cable between the **SYNC** and **Ext Trig** connectors.

- H. Reduce the sinusoidal signal frequency to 0.33 Hz with an amplitude of 8 VPP. Oscilloscope settings are:

Vertical Controls

Ch. 1: 2 Volts/Div
Coupling: DC

Horizontal Controls

Time/Div: 500 ms

Trigger Controls(Press **Mode/Coupling**)

Source: 1
Mode: Edge
Slope: positive (up arrow)
Coupling: DC
Level: 0V

1. The trace should be repetitive, and beginning at nearly the same point (horizontal and vertical) each time. If it does not, check all settings carefully and get help if necessary.
2. How long does the sweep circuit require to move the trace across the oscilloscope screen?
3. What is the period of the signal from the function generator?
4. Sketch the trace you see in your notebook. Label each axis!
5. Change the trigger **Slope** to negative (down arrow). In another color, sketch the trace you see on the preceding graph. How does it differ?

What is the sign of the derivative of the signal with respect to time at the beginning of the trace when the **Slope** setting is positive? Is negative? Return the **Slope** setting to positive.

6. What is the magnitude and polarity sign of the voltage when the trace begins? (Do you remember where 'zero time' is?)!

Rotate the trigger **Level** control to a value of 2V. Now what is the magnitude and polarity sign of the voltage when the trace begins?

Set the trigger level to 5V. What happened? Reset the level to 0V.

7. Study, on your own, various combinations of settings of the **Trigger** controls. Increase the signal frequency to 1 kHz and the **Horizontal** knob to 200 μ s. If you are not sure what you should be observing, ask for help.

When finished, reset the function generator and oscilloscope to the settings given at the beginning of this section (0.33 Hz, etc.) and continue.

8. The drawing of Figure 7 shows a block diagram of the trigger system. The trigger circuit sends a signal to the sweep oscillator telling it to initiate a display. This happens only when the signal has certain features, namely that its amplitude and slope are what the viewer requires. In the example we have been using, the signal has the proper sign and slope once every 3 seconds.

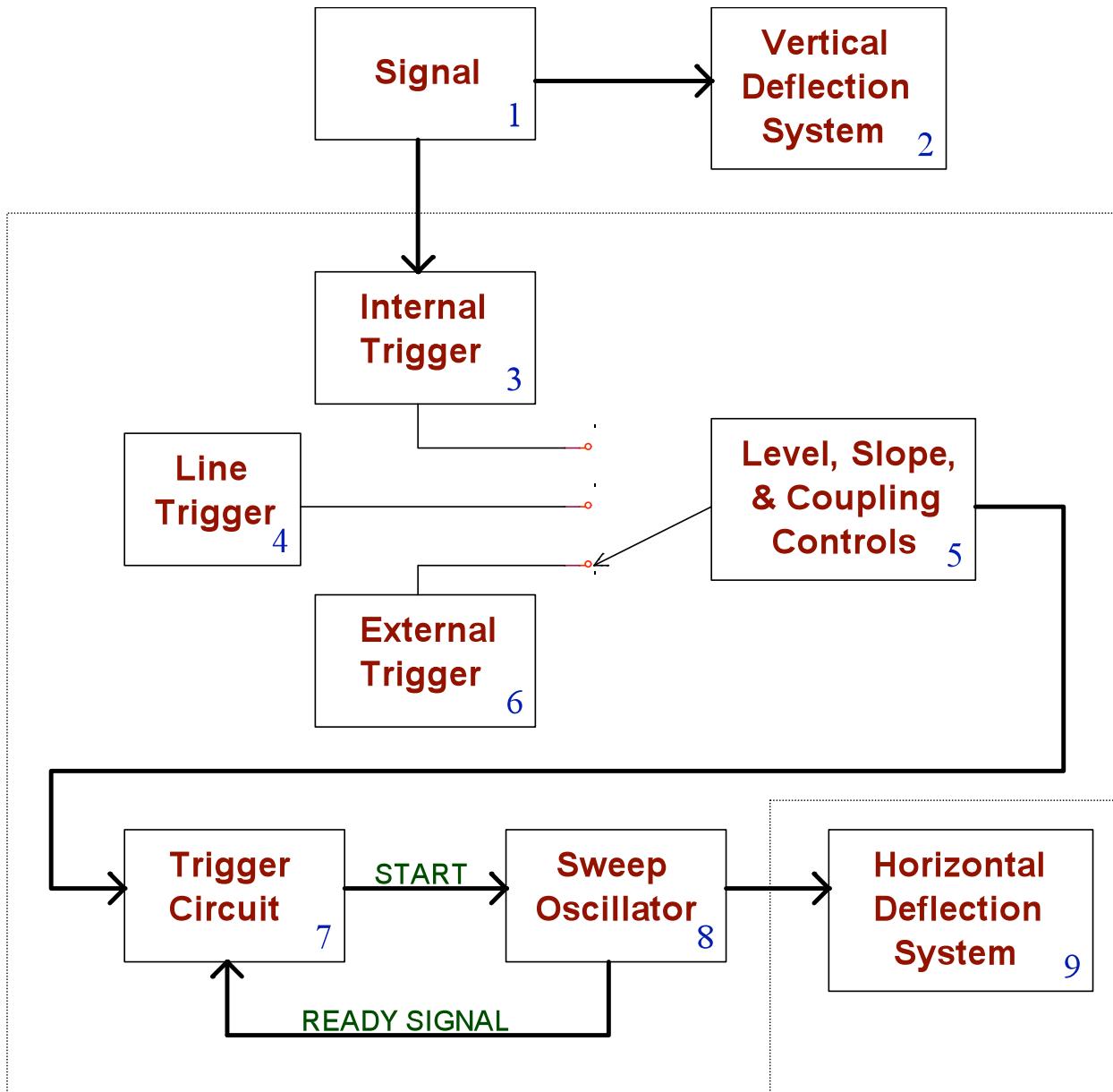

Figure 7. Block diagram of Trigger System (inside dashed-line box)

9. Increase the **Horizontal** control back to 500 ms. What is the period required for one trace? Since the signal period is still 3 seconds, you see about $1 \frac{2}{3}$ repetitions of the signal.
10. Select an **Ext** trigger source. The trace should disappear. In this mode, we must provide a signal to the **Ext Trig** terminal. The slope and level controls now apply to the triggering signal, which may or may not be the signal we are viewing. We will see an important application of external input triggering in the next section. At present, this is an improper setting for the trigger source.

VII. Dual Trace Operation

Until now you have probably not used the oscilloscope probe to make measurements with the oscilloscope. When using an oscilloscope it is very important to use a proper oscilloscope probe. From now on you should always use an oscilloscope probe to make measurements with the oscilloscope. The only exceptions would be if it is physically not possible to connect the probe where you will make your measurement, or if you are connected to another piece of test equipment, such as a function generator, with an appropriate (shielded) cable, such as a BNC to BNC cable.

There are a number of advantages the test probe has over using 'banana to pin' cables paired with a BNC to banana connector. If you try taking the exact same measurements using both methods, you will notice one major difference: the test probe provides a cleaner signal. This results from a number of factors.

First, the coax used in the test probe is specifically designed to minimize the capacitive effects that occur when simply using wires. The test probe itself has a $9M\Omega$ resistor in series with the probe tip. This reduces loading effects (namely, loading capacitance) the probe has on the circuit. In addition, this creates a 10x voltage divider since the typical oscilloscope input impedance is $1M\Omega$. So as long as the probe is compensated correctly, it will provide 10x attenuations from DC to any AC frequency range you will use in this course.

Another advantage of using the test probe is that it eliminates noise in the measurement by eliminating the number of connections between the device under test and the oscilloscope. As well as causing reflections back into your circuit, the BNC to banana connector can pick up a substantial amount of ambient noise. If you connect a 'banana to pin' cable to it, you will have created a nice antenna. You should be able to measure a 60Hz signal on the oscilloscope with this setup. If you create a loop with the cable, you can even pick up the local radio station!

In order to obtain a clean measurement, it is important to use the oscilloscope test probe. By reducing loading capacitance, and reducing measured ambient noise, the oscilloscope test probe provides a cleaner, more accurate measurement.

Connect the circuit of Figure 8. Use parts from your component kit and your superstrip. Remember to connect channels 1 and 2 to the circuit with oscilloscope probes.

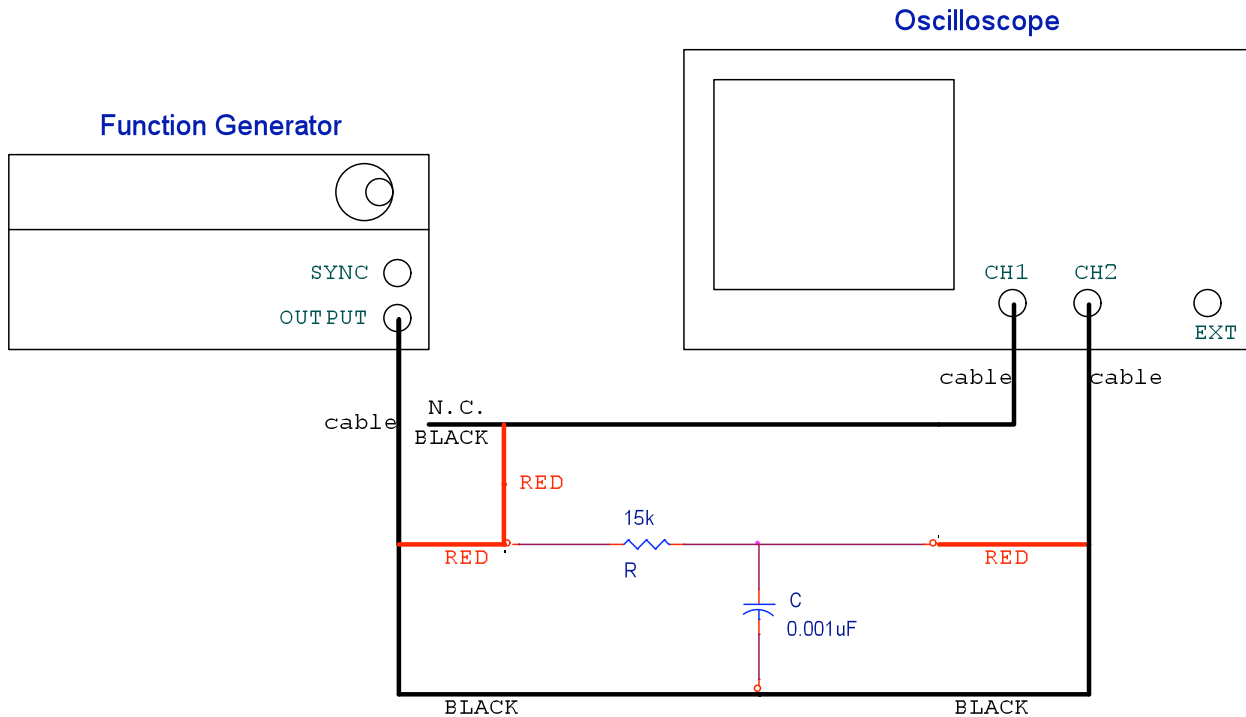

Figure 8. Study of an RC circuit

In studying this circuit diagram, note the following:

1. The RC circuit is fed with a 10 kHz sinusoidal voltage whose amplitude is to be adjusted to 8 volts peak-to-peak.
2. The source voltage will be displayed on the oscilloscope via channel 1.
3. The capacitor voltage will be displayed on the oscilloscope via channel 2.

The oscilloscope controls should be set as follows.

Vertical Controls

Channel 1 and Channel 2: On
1 Volt/Div
DC Coupling

Position Controls: Each channel's vertical **Position** knob should be adjusted so that, with no signals applied, the horizontal traces coincide with the x-axis (or center axis) of the grid.
[Position () = 0 V]

*Horizontal Controls*Time/Div: 20 μ s*Trigger Controls*

Source: 1

Mode: Auto Lvl

Slope: positive

Coupling: AC

Level: approximately 50%

Holdoff: minimum

After checking the settings of the oscilloscope controls, turn on the function generator and adjust its output level so that the sinusoidal signal displayed on channel 1 is 8 volts peak-to-peak. Set the frequency to 10 kHz.

Sketch the display seen on the oscilloscope in your notebook. In making the sketch, note that the capacitor voltage is not in phase with the source voltage, i.e., the capacitor voltage and source voltage do not reach their maximum values at the same time. Measure the phase difference (in degrees) between the two signals – $\theta = (360)(\Delta t)(f)$ it should be about 43° , (use time cursors to get Δt), with the capacitor voltage lagging (trailing) the signal voltage. If necessary, ask your instructor for assistance with this important step. When finished, disassemble your circuit.

VIII. Calibration Check

- A. Set **Probe** to **10X** (Channel 1 menu). Connect the oscilloscope calibrating signal terminal (next to the intensity control) to the channel 1 input. Use an oscilloscope probe.
- B. Press the **Auto-scale** button.
- C. You should see a square wave with approximately a 5.0 cm deflection.
- D. The waveform should be a near perfect square wave. If the capacitance of the probe is not calibrated correctly, you will see a rounded off edge (instead of sharp edge) on the leading and trailing edges of the signal.
- E. Check the calibration of channel 2 also. Move the BNC connector of the probe to the channel 2 input and press **Auto-scale**. Repeat steps C and D above.
- F. Note: With the new equipment in the lab, this calibration is usually not needed. However, on older scopes, it is usually a good idea to perform this calibration check. If the square wave is rounded off, you may need to use an adjustment tool on the small screw on the BNC part of the probe to calibrate the capacitance of the probe until you see a near-ideal square wave.

- G. Disconnect the probe from the calibrating signal terminal.

NOTE: IT IS SUGGESTED THAT YOU ALWAYS MAKE THIS QUICK CHECK OF THE oscilloscope BEFORE MAKING ANY MEASUREMENTS AT THE BEGINNING OF EACH DAY. IT CAN SAVE A LOT OF TIME BY PREVENTING USELESS DATA.

IX. Conclusion

- A. You have now had the opportunity to examine most of the functions of this oscilloscope. At this time, review any portion of the exercise that was not clear to you. There may be some additional measurements that you would like to try. Do. This booklet is now your personalized instruction manual for this instrument.
- B. Other Oscilloscope features to investigate:
1. Delayed time base
 2. Save/Recall
 3. Cursor measurements
 4. XY display mode
- C. Other Function Generator features to investigate:
- View arbitrary waveforms
- D. Turn off the equipment. Disconnect and hang up all the cables.