ZedBoard

(Zynq™ Evaluation and Development)
Hardware User's Guide



Version 1.9
January 29th, 2013

Table of Contents

1	INTRODUCTION.....	2
1.1	ZYNQ BANK PIN ASSIGNMENTS	4
2	FUNCTIONAL DESCRIPTION.....	5
2.1	ALL PROGRAMMABLE SOC	5
2.2	MEMORY.....	5
2.2.1	DDR3.....	5
2.2.2	SPI Flash.....	8
2.2.3	SD Card Interface.....	10
2.3	USB.....	11
2.3.1	USB OTG.....	11
2.3.2	USB-to-UART Bridge.....	11
2.3.3	USB-JTAG.....	12
2.3.4	USB circuit protection.....	13
2.4	DISPLAY AND AUDIO.....	13
2.4.1	HDMI Output.....	13
2.4.2	VGA Connector.....	16
2.4.3	I2S Audio Codec.....	17
2.4.4	OLED.....	18
2.5	CLOCK SOURCES.....	18
2.6	RESET SOURCES	18
2.6.1	Power-on Reset (PS_POR_B).....	18
2.6.2	Program Push Button Switch.....	19
2.6.3	Processor Subsystem Reset.....	19
2.7	USER I/O	19
2.7.1	User Push Buttons.....	19
2.7.2	User DIP Switches.....	19
2.7.3	User LEDs.....	20
2.8	10/100/1000 ETHERNET PHY	20
2.9	EXPANSION HEADERS	21
2.9.1	LPC FMC Connector.....	21
2.9.2	Digilent Pmod™ Compatible Headers (2x6).....	22
2.9.3	Agile Mixed Signaling (AMS) Connector, J2.....	23
2.10	CONFIGURATION MODES.....	26
2.10.1	JTAG.....	27
2.11	POWER	28
2.11.1	Primary Power Input.....	28
2.11.2	On/Off Switch.....	28
2.11.3	Regulators.....	28
2.11.4	Sequencing.....	29
2.11.5	Power Good LED.....	30
2.11.6	Power Estimation.....	30
2.11.7	Testing.....	31
2.11.8	Probes.....	31
3	ZYNQ-7000 AP SOC BANKS	32
3.1	ZYNQ-7000 AP SOC BANK VOLTAGES	33
4	JUMPER SETTINGS.....	34
5	MECHANICAL	36

1 Introduction

The ZedBoard is an evaluation and development board based on the Xilinx Zynq™-7000 All Programmable SoC (AP SoC). Combining a dual Corex-A9 Processing System (PS) with 85,000 Series-7 Programmable Logic (PL) cells, the Zynq-7000 AP SoC can be targeted for broad use in many applications. The ZedBoard's robust mix of on-board peripherals and expansion capabilities make it an ideal platform for both novice and experienced designers. The features provided by the ZedBoard consist of:

- Xilinx® XC7Z020-1CLG484CES Zynq-7000 AP SoC
 - Primary configuration = QSPI Flash
 - Auxiliary configuration options
 - § Cascaded JTAG
 - § SD Card
- Memory
 - 512 MB DDR3 (128M x 32)
 - 256 Mb QSPI Flash
- Interfaces
 - USB-JTAG Programming using Digilent SMT1-equivalent circuit
 - § Accesses PL JTAG
 - § PS JTAG pins connected through PS Pmod
 - 10/100/1G Ethernet
 - USB OTG 2.0
 - SD Card
 - USB 2.0 FS USB-UART bridge
 - Five Digilent Pmod™ compatible headers (2x6) (1 PS, 4 PL)
 - One LPC FMC
 - One AMS Header
 - Two Reset Buttons (1 PS, 1 PL)
 - Seven Push Buttons (2 PS, 5 PL)
 - Eight dip/slide switches (PL)
 - Nine User LEDs (1 PS, 8 PL)
 - DONE LED (PL)
- On-board Oscillators
 - 33.333 MHz (PS)
 - 100 MHz (PL)
- Display/Audio
 - HDMI Output
 - VGA (12-bit Color)
 - 128x32 OLED Display
 - Audio Line-in, Line-out, headphone, microphone
- Power
 - On/Off Switch
 - 12V @ 5A AC/DC regulator
- Software
 - ISE® WebPACK Design Software
 - License voucher for ChipScope™ Pro locked to XC7Z020

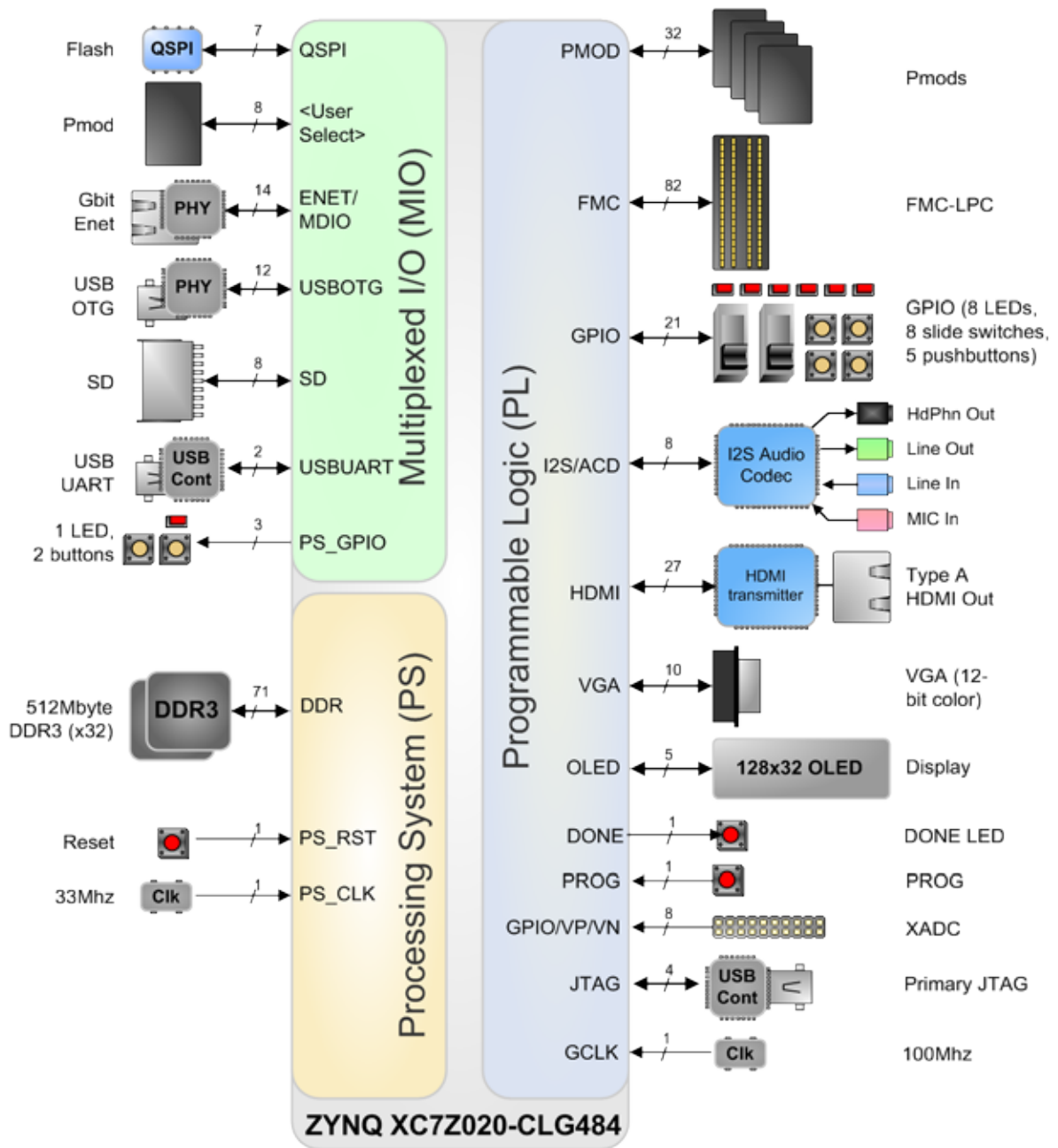

Figure 1 – ZedBoard Block Diagram

1.1 Zynq Bank Pin Assignments

The following figure shows the Zynq bank pin assignments on the ZedBoard followed by a table that shows the detailed I/O connections.

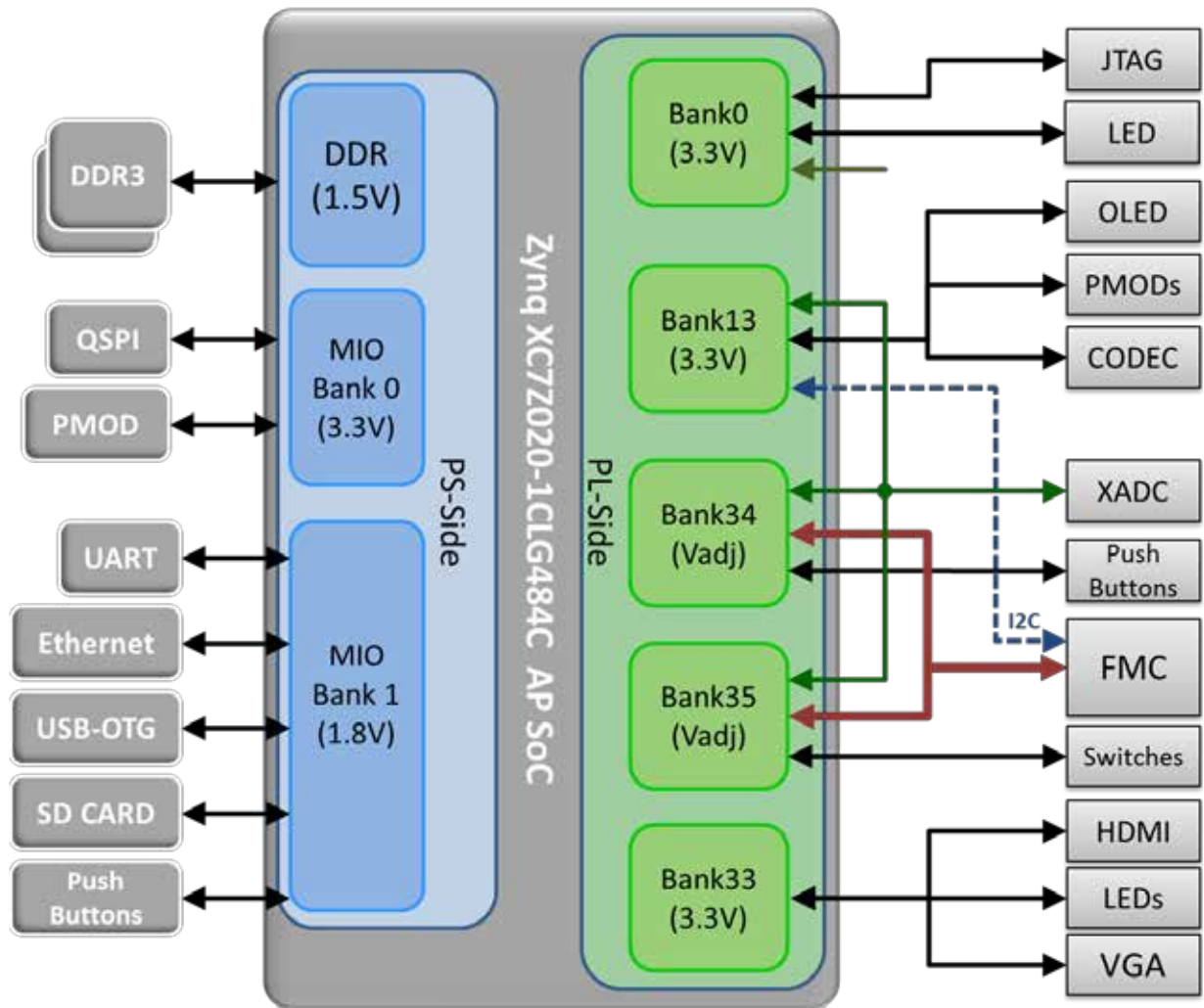

Figure 2 - Zynq Z7020 CLG484 Bank Assignments

2 Functional Description

2.1 All Programmable SoC

The ZedBoard features a Xilinx Zynq XC7Z020-1CLG484 All Programmable SoC (AP SoC). Initial ZedBoards ship with Engineering Sample "CES" grade silicon. Later shipments will eventually switch to production "C" grade silicon once they become available. The Zynq-7000 AP SoC part markings indicate the silicon grade.

2.2 Memory

Zynq contains a hardened PS memory interface unit. The memory interface unit includes a dynamic memory controller and static memory interface modules.

2.2.1 DDR3

The ZedBoard includes two Micron MT41J128M16HA-15E:D DDR3 memory components creating a 32-bit interface. As of August 2012, this device has been marked by Micron for end-of-life. There are several options that Micron offers for a replacement. ZedBoard will likely migrate to the MT41K128M16JT-125 device, although this is pending validation. The DDR3 is connected to the hard memory controller in the Processor Subsystem (PS) as outlined in the Zynq datasheet.

The multi-protocol DDR memory controller is configured for 32-bit wide accesses to a 512 MB address space. The PS incorporates both the DDR controller and the associated PHY, including its own set of dedicated I/Os. DDR3 memory interface speeds up to 533MHz (1066Mbs) are supported.

The DDR3 uses 1.5V SSTL-compatible inputs. DDR3 Termination is utilized on the ZedBoard. The Zynq-7000 AP SoC and DDR3 have been placed close together keeping traces short and matched.

DDR3 on the PS was routed with 40 ohm trace impedance for single-ended signals, and DCI resistors (VRP/VRN) as well as differential clocks set to 80 ohms. Each DDR3 chip needs its own 240-ohm pull-down on ZQ.

DDR-VDDQ is set to 1.5V to support the DDR3 devices selected. DDR-VTT is the termination voltage which is $\frac{1}{2}$ DDR-VDDQ. DDR-VREF is a separate buffered output that is equal to $\frac{1}{2}$ nominal DDR-VDDQ. The DDR-VREF is isolated to provide a cleaner reference for the DDR level transitions.

The PCB design guidelines outlined in Zynq datasheet must be followed for trace matching, etc.

Table 1 - DDR3 Connections

Signal Name	Description	Zynq pin	DDR3 pin
DDR_CK_P	Differential clock output	N4	J7
DDR_CK_N	Differential clock output	N5	K7
DDR_CKE	Clock enable	V3	K9
DDR_CS_B	Chip select	P6	L2
DDR_RAS_B	RAS row address select	R5	J3
DDR_CAS_B	RAS column address select	P3	K3
DDR_WE_B	Write enable	R4	L3
DDR_BA[2:0]	Bank address	PS_DDR_BA[2:0]	BA[2:0]
DDR_A[14:0]	Address	PS_DDR_A[14:0]	A[14:0]
DDR_ODT	Output dynamic termination	P5	K1
DDR_RESET_B	Reset	F3	T2
DDR_DQ[31:0]	I/O Data	PS_DDR_[31:0]	DDR3_DQ pins
DDR_DM[3:0]	Data mask	PS_DDR_DM[3:0]	LDM/UDM x2
DDR_DQS_P[3:0]	I/O Differential data strobe	PS_DDR_DQS_P[3:0]	UDQS/LDQS
DDR_DQS_N[3:0]	I/O Differential data strobe	PS_DDR_DQS_N[3:0]	UDQS#/LDQS#
DDR_VRP	I/O Used to calibrate input termination	N7	N/A
DDR_VRN	I/O Used to calibrate input termination	M7	N/A
DDR_VREF[1:0]	I/O Reference voltage	H7, P7	H1

For best DDR3 performance, DRAM training is enabled for write leveling, read gate, and read data eye options in the PS Configuration Tool in Xilinx Platform Studio (XPS). The PS Configuration tools' Memory Configuration Wizard contains two entries to allow for DQS to Clock Delay and Board Delay information to be specified for each of the four byte lanes. These parameters are specific to every PCB design. [Xilinx Answer Record 46778](#) provides a tool for calculating these parameters by a printed circuit board design engineers. The Excel worksheet file **ar46778_board_delay_calc.xlsx** included in the answer record provides instructions in the worksheet for calculating these board training details based upon specific trace lengths for certain DDR3 signals. Using the information from the trace length reports pertaining to the DDR3 interface for ZedBoard these delay values can be recreated by following the directions found in the Excel worksheet.

The PCB lengths are contained in the ZedBoard PCB trace length reports. The DQS to CLK Delay and Board Delay values are calculated specific to the ZedBoard memory interface PCB design. The AR46778 worksheet allows for up to 4 memory devices to be configured for DDR3 4x8 flyby topology. Note that ZedBoard is configured for DDR3 2x16 flyby routing topology. The first two clock trace midpoint values (CLK0 and CLK1) are used to represent the Micron device electrically nearest to 7Z020 (IC26) and the second two clock trace midpoint values (CLK2 and

CLK3) are used to represent the Micron device electrically furthest from 7Z020 (IC25). The worksheet calculation results are shown in the following table.

Table 2 - DDR3 Worksheet Calculations

Pin Group	Length (mm)	Length (mils)	Package Length (mils)	Total Length (mils)	Propagation Delay (ps/inch)	Total Delay (ns)	DQS to CLK Delay (ns)	Board Delay (ns)
CLK0	55.77	2195.9	470	2665.9	160	0.427		
CLK1	55.77	2195.9	470	2665.9	160	0.427		
CLK2	41.43	1631.1	470	2101.1	160	0.336		
CLK3	41.43	1631.1	470	2101.1	160	0.336		
DQS0	51.00	2008.0	504	2512.0	160	0.402	0.025	
DQS1	50.77	1998.8	495	2493.8	160	0.399	0.028	
DQS2	41.59	1637.6	520	2157.6	160	0.345	-0.009	
DQS3	41.90	1649.4	835	2484.4	160	0.398	-0.061	
DQ[7:0]	50.63	1993.3	465	2458.3	160	0.393		0.410
DQ[15:8]	50.71	1996.4	480	2476.4	160	0.396		0.411
DQ[23:16]	40.89	1609.9	550	2159.9	160	0.346		0.341
DQ[31:24]	40.58	1597.8	780	2377.8	160	0.380		0.358

The DQS to CLK Delay fields in the PS7 DDR Configuration window should be populated using the corresponding values from the previous table.

The configuration fields of the tool may not allow you to input a negative delay value, this is a known problem with the 14.1 tools and scheduled for correction in the 14.2 tools release. In the case of DQS2 and DQS3 fields for DQS to CLK Delay, simply enter a value of zero rather than the negative delay values. This is an acceptable workaround since the calculated values are relatively close to zero and the values provided in these fields are used as initial values for the read/write training for DDR3. Keep in mind for LPDDR2 there is no write leveling, and for DDR2 there is no training whatsoever. In these memory use cases, the accuracy of the trace length info is more important. This is covered in further detail in section 10.6.8 of the [Xilinx Zynq TRM, UG585](#).

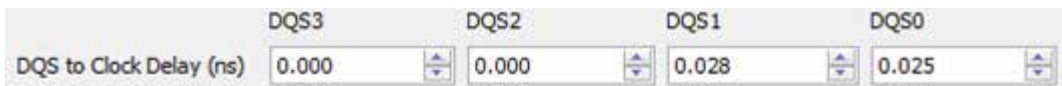

Figure 3 - DQS to Clock Delay Settings

The Board Delay fields in the PS7 DDR Configuration window should be populated using the corresponding values from the table above.

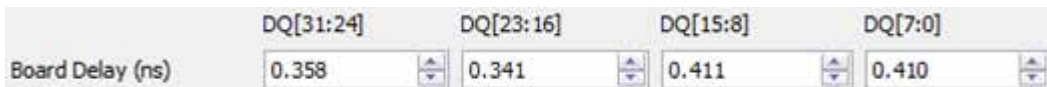

Figure 4 - DDR3 Board Delay Settings

2.2.2 SPI Flash

The ZedBoard features a 4-bit SPI (quad-SPI) serial NOR flash. The Spansion S25FL256S is used on this board. The Multi-I/O SPI Flash memory is used to provide non-volatile code, and data storage. It can be used to initialize the PS subsystem as well as configure the PL subsystem (bitstream). Spansion provides Spansion Flash File System (FFS) for use after booting the Zynq-7000 AP SoC.

The relevant device attributes are:

- 256Mbit
- x1, x2, and x4 support
- Speeds up to 104 MHz, supporting Zynq configuration rates @ 100 MHz
 - In Quad-SPI mode, this translates to 400Mbs
- Powered from 3.3V

The SPI Flash connects to the Zynq-7000 AP SoC supporting up to Quad-I/O SPI interface. This requires connection to specific pins in MIO Bank 0/500, specifically MIO[1:6,8] as outlined in the Zynq datasheet. Quad-SPI feedback mode is used, thus `qspi_sclk_fb_out/MIO[8]` is connected to a 20K pull-up resistor to 3.3V. This allows a QSPI clock frequency greater than FQSPICLK2.

Note: Zynq only supports 24-bit addressing, however the full capacity of the 256Mb Flash can be accessed via internal bank switching. As of now the S25FL256S is not supported in iMPACT.

Note: 14.x is required for in-direct QSPI Flash Programming.

Table 3 – QSPI Flash Pin Assignment and Definitions

Signal Name	Description	Zynq Pin	MIO	QSPI Pin
DQ0	Data0	A2 (Bank MIO0/500)	1:6	5
DQ1	Data1	F6 (MIO Bank 0/500)		2
DQ2	Data2	E4 (MIO Bank 0/500)		3
DQ3	Data3	A3 (MIO Bank 0/500)		7
SCK	Serial Data Clock	A4 (MIO Bank 0/500)		6
CS	Chip Select	A1 (MIO Bank 0/500)		1
FB Clock	QSPI Feedback	E5 (MIO Bank 0/500)	8	N/C

Note: The QSPI data and clock pins are shared with the Boot Mode jumpers.

Two packages can be used on the ZedBoard; SO-16 and WSON. For the WSON package, there is a heat sink slug under the package that is not connected to any signal on the PCB.

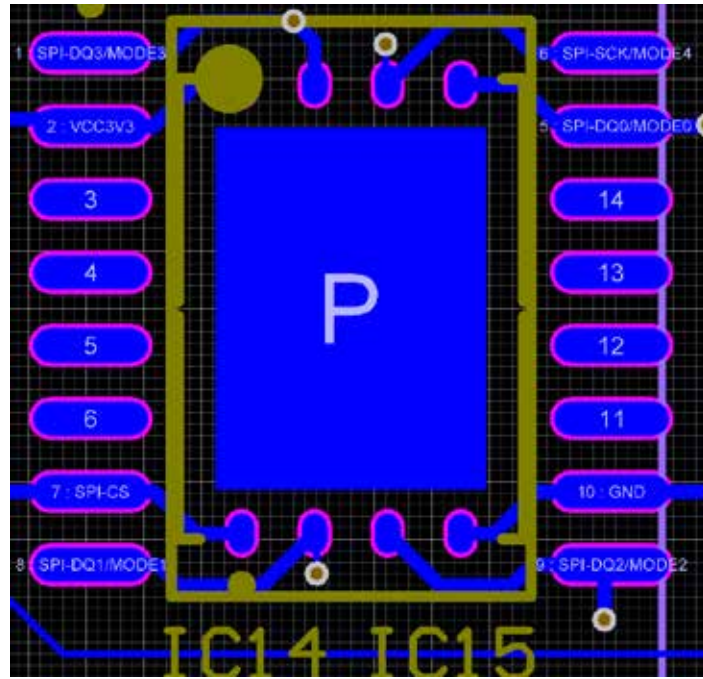

Figure 5 - Overlying Packages for SPI Flash

2.2.3 SD Card Interface

The Zynq PS SD/SDIO peripheral controls communication with the ZedBoard SD Card (A 4GB Class 4 card is included in the ZedBoard kit.) The SD card can be used for non-volatile external memory storage as well as booting the Zynq-7000 AP SoC. PS peripheral sd0 is connected through Bank 1/501 MIO[40-47], including, Card Detect and Write Protect.

The SD Card is a 3.3V interface but is connected through MIO Bank 1/501 (1.8V). Therefore, a TI TXS02612 level shifter performs this translation. The TXS02612 is a 2-port SDIO port expander with level translation. ZedBoard only makes use of one of these parts. TI offered an alternative TXS0206 device, but the 0.4mm pitch of that device's packaging was too fine for our manufacturer.

Based on the Zynq TRM, host mode is the only mode supported.

The ZedBoard SD Card is connected through a 9-pin standard SD card connector, J12, TE [2041021-1](http://www.teconnectivity.com/Products/TE-2041021-1). A Class 4 card or better is recommended.

Note: To use the SD Card, JP6 must be shorted.

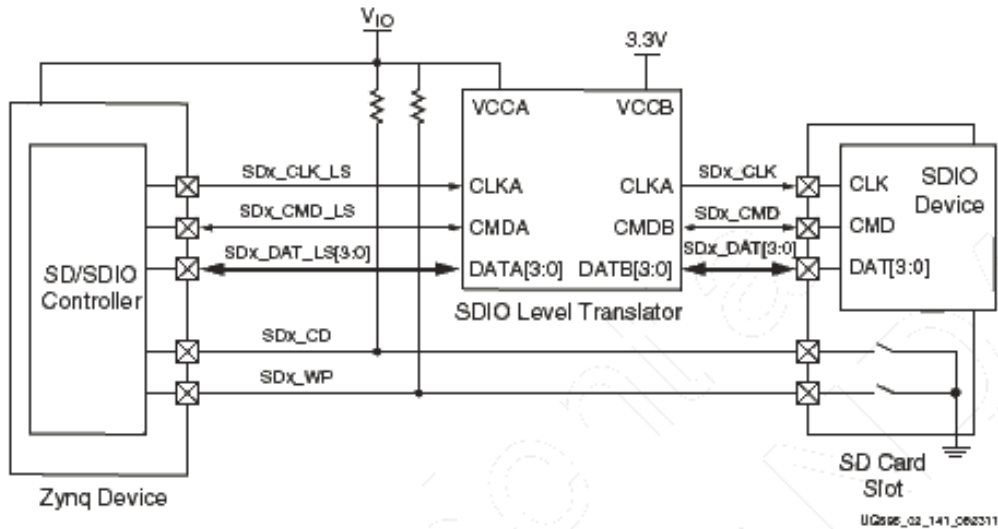

Figure 6 - SD Card Interface

Table 4 – SD Card Pin Assignment and Definitions

Signal Name	Description	Zynq Pin	MIO	Level Shift Pin	SD Card Pin
CLK	Clock	E14 (MIO Bank 1/501)	40	Pass-Thru	5
CMD	Command	C8 ((MIO Bank 1/501)	41	Pass-Thru	2
Data[3:0]	Data	MIO Bank 1/501 D0: D8 D1: B11 D2: E13 D3: B9	42:45	Pass-Thru	Data Pins 7 8 9 1
CD	Card Detect	B10 (MIO Bank 1/501)	47	Pass-Thru	CD
WP	Write Protect	D12 ((MIO Bank 1/501)	46	Pass-Thru	WP

2.3 USB

2.3.1 USB OTG

Warning: After the design of the ZedBoard was complete, a timing incompatibility between the TUSB1210 PHY and Zynq was discovered. The TUSB1210 is not recommended for new designs with Xilinx Zynq. Please refer to the ZedBoard Errata for more details.

ZedBoard implements one of the two available PS USB OTG interfaces. An external PHY with an 8-bit ULPI interface is required. A TI TUSB1210 Standalone USB Transceiver Chip is used as the PHY. The PHY features a complete HS-USB Physical Front-End supporting speeds of up to 480Mbps. This part is available in a 32-pin QFN package. VCCio for this device is 1.8V and cannot be connected through level shifters. The PHY is connected to MIO Bank 1/501, which is powered at 1.8V. Additionally the USB chip must clock the ULPI interface which requires an oscillator. A Fox XPRESSO oscillator (767-26-31) is used on ZedBoard.

The external USB interface connects through a TE [1981584-1](#).

The usb0 peripheral is used on the PS, connected through MIO[28-39] in MIO Bank 1/501.

This USB port will not power the board. However, ZedBoard provides 5V when in Host or OTG modes. REFCLK pin of TUSB1210 is tied to ground as the Zynq-7000 AP SoC will drive the CLOCK input of this part.

Table 5 - USB OTG Pin Assignment and Definitions

Signal Name	Description	Zynq Pin	MIO	TUSB1210 Pin	USB Conn Pin
OTG_Data[8:0]	USB Data lines	MIO Bank 1/501	28:39	Data[7:0]	N/C
OTG_CLOCK	USB Clock	MIO Bank 1/501		26	N/C
OTG_DIR	ULPI DIR output signal	MIO Bank 1/501		31	N/C
OTG_STP	ULPI STP input signal	MIO Bank 1/501		29	N/C
OTG_NXT	ULPI NXT output signal	MIO Bank 1/501		2	N/C
OTG_CS	USB Chip Select			11	N/C
DP	DP pin of USB Connector	N/C		18	2
DM	DM pin of USB Connector	N/C		19	3
ID	Identification pin of the USB connector	N/C		23	4
OTG_RESET_B	Reset	MIO Bank 1/501		27	N/C
OTG_VBUS_OC	VBus Output Control	Bank 34		L16	TPS2051

See the Jumper Settings section for configuring the USB interface for Host, Device and OTG mode. The jumpers control the Vbus supply as well.

2.3.2 USB-to-UART Bridge

The ZedBoard implements a USB-to-UART bridge connected to a PS UART peripheral. A Cypress CY7C64225 USB-to-UART Bridge device allows connection to a host computer. The USB/UART device connects to the USB Micro B connector, J14, (TE 1981584-1) on the board. Only basic TXD/RXD connection is implemented. If flow control is required this can be added through Extended MIO on a PL-Pmod™.

Cypress provides royalty-free Virtual COM Port (VCP) drivers which permit the CY7C64225 USB-to-UART bridge to appear as a COM port to host computer communications application software

(for example, HyperTerm or Tera Term). Please refer to the CY7C64225 Setup Guide posted on zedboard.org for detailed instructions for installing the driver.

The UART 1 Zynq PS peripheral is accessed through MIO[48:49] in MIO Bank 1/501 (1.8V). Since the CY7C64225 device requires either 3.3V or 5V signaling, a TI TXS0102 level shifter is used to level shift between 3.3V and 1.8V.

This USB port will not power the board. Therefore, Vbus needs to be connected to 3.3V through a 1K Ω series resistor. The Wake pin, pin 22, connects to GND. A 24 Ω series resistor was placed on each of the data lines, D+ and D-.

Table 6 – CY7C6 Connections

UART Function in Zynq	Zynq Pin	MIO	Schematic Net Name	CY7C6 Pin	UART Function in CY7C64225
TX, data out	D11 (MIO Bank 1/501)	48:49	USB_1_RXD	23	RXD, data in
RX, data in	C14 (MIO Bank 1/501)		USB_1_TXD	4	TXD, data out

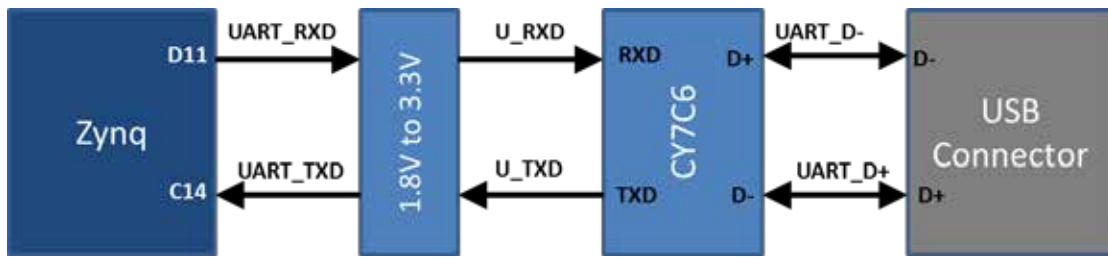

Figure 7 – USB-UART Bridge Interface

2.3.3 USB-JTAG

The ZedBoard provides JTAG functionality based on the Digilent USB High Speed JTAG Module, SMT1 device. This USB-JTAG circuitry is fully supported and integrated into Xilinx ISE tools, including iMPACT, ChipScope, and SDK Debugger. Designers who want to re-use this circuit on their board can do so by acquiring these modules from Avnet.

<http://www.em.avnet.com/en-us/design/drc/Pages/Digilent-JTAG-SMT1-Surface-Mount-Programming-Module.aspx>

The JTAG is available through a Micro B USB connector, J17, TE [1981568-1](#). TCK has a series termination resistor, 20-30 Ω , to prevent signal integrity issues.

For the JTAG Chain setup, please refer to the Configuration section.

2.3.4 USB circuit protection

All USB data lines, D+/-, are protected with a TE SESD0402Q2UG-0020-090.

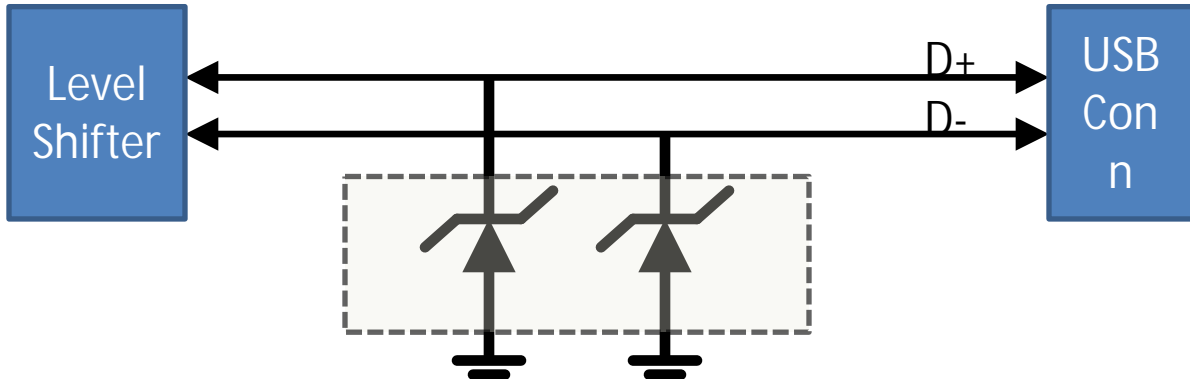

Figure 8 – ESD Protection

2.4 Display and Audio

2.4.1 HDMI Output

An Analog Devices ADV7511 HDMI Transmitter provides a digital video interface to the ZedBoard. This 225MHz transmitter is HDMI 1.4- and DVI 1.0-compatible supporting 1080p60 with 16-bit, YCbCr, 4:2:2 mode color.

The ADV7511 supports both S/PDIF and 8-channel I2S audio. The S/PDIF can carry compressed audio including Dolby® Digital, DTS®, and THX®. There is an independent DPDIF input and output. The I2S interface is not connected on ZedBoard. Analog Devices offers Linux drivers and reference designs illustrating how to interface to this device.

The HDMI Transmitter has 25 connections to Bank 35 (3.3V) of the Zynq-7000 AP SoC:

Table 7 - HDMI Interface Connections

Signal Name	Description	Zynq pin	ADV7511 pin
HDP	Hot Plug Detect signal input	N/C	30
HD-INT	Interrupt signal output	W16	45
HD-SCL	I2C Interface. Supports CMOS logic levels from 1.8V to 3.3V	AA18	55
HD-SDA		Y16	56
HD-CLK	Video Clock Input. Supports typical CMOS logic levels from 1.8V up to 3.3V	W18	79
HD-VSYNC	Vertical Sync Input (Not required if using embedded syncs)	W17	2
HD-HSYNC	Horizontal Sync Input (Not required if using embedded syncs)	V17	98
HD-DE	Data Enable signal input for Digital Video (Not required if using embedded syncs)	U16	97
HD_D[15:0]	Video Data Input	Bank 35 D0: Y13 D1: AA12 D2: AA14 D3: Y14 D4: AB15 D5: AB16 D6: AA16 D7: AB17 D8: AA17 D9: Y15 D10: W13 D11: W15 D12: V15 D13: U17 D14: V14 D15: V13	88 87 86 85 84 83 82 81 80 78 74 73 72 71 70 69
HD-SPDIF	Sony/Philips Digital Interface Audio Input	U15	10
HD-SPDIFO	Sony/Philips Digital Interface Audio Output	Y18	46

Figure 2 Timing for Video Data Interface

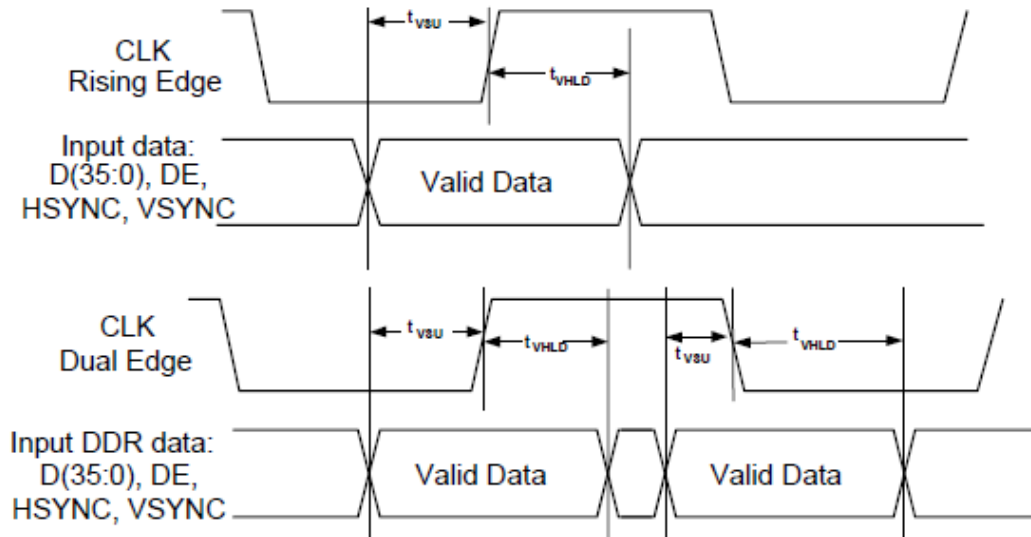

Figure 9 - HDMI Video Interface Timing

The HDMI transmitter connects externally via a HDMI Type A connector, J9, TE [1903015-1](#).

Circuit protection for the HDMI interface is provided by a Tyco Electronics SESD0802Q4UG.

2.4.2 VGA Connector

The ZedBoard also allows 12-bit color video output through a through-hole VGA connector, TE [4-1734682-2](#). Each color is created from resistor-ladder from four PL pins.

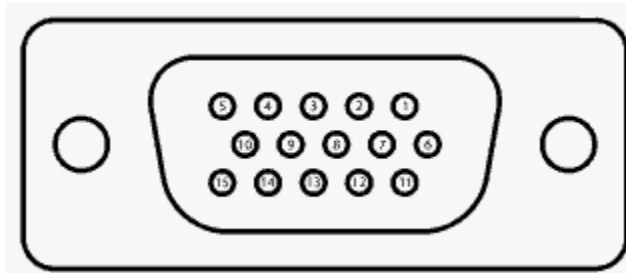

Figure 10 - DB15

Table 8 - VGA Connections

VGA Pin	Signal	Description	Zynq Pin
1	RED	Red video	V20, U20, V19, V18
2	GREEN	Green video	AB22, AA22, AB21, AA21
3	BLUE	Blue video	Y21, Y20, AB20, AB19
4	ID2/RES	formerly Monitor ID bit 2	NC
5	GND	Ground (HSync)	NC
6	RED_RTN	Red return	NC
7	GREEN_RTN	Green return	NC
8	BLUE_RTN	Blue return	NC
9	KEY/PWR	formerly key	NC
10	GND	Ground (VSync)	NC
11	ID0/RES	formerly Monitor ID bit 0	NC
12	ID1/SDA	formerly Monitor ID bit 1	NC
13	HSync	Horizontal sync	AA19
14	VSync	Vertical sync	Y19
15	ID3/SCL	formerly Monitor ID bit 3	NC

2.4.3 I2S Audio Codec

An Analog Devices ADAU1761 Audio Codec provides integrated digital audio processing to the Zynq-7000 AP SoC. It allows for stereo 48KHz record and playback. Sample rates from 8KHz to 96KHz are supported. Additionally, the ADAU1761 provides digital volume control. The Codec can be configured using Analog Devices SigmaStudio™ for optimizing audio for specific acoustics, numerous filters, algorithms and enhancements. Analog Devices provides Linux drivers for this device.

http://www.analog.com/en/content/cu_over_sigmastudio_graphical_dev_tool_overview/fca.html

The Codec interface to the Zynq-7000 AP SoC consists of the following connections:

Table 9 - CODEC Connections

Signal Name	Description	Zynq pin	ADAU1761 pin
AC-ADR0	I2C Address Bit 0/SPI Latch Signal	AB1	3
AC-ADR1	I2C Address Bit 1/SPI Data Input	Y5	30
AC-MCLK	Master Clock Input	AB2	2
AC-GPIO2	Digital Audio Bit Clock Input/Output	AA6	28
AC-GPIO3	Digital Audio Left-Right Clock Input/Output	Y6	29
AC-GPIO0	Digital Audio Serial-Data DAC Input	Y8	27
AC-GPIO1	Digital Audio Serial Data ADC Output	AA7	26
AC-SDA	I2C Serial Data interface	AB5	31
AC-SCK	I2C Serial Data interface	AB4	32

The Codec connects to the following connectors:

Table 10 - External Codec Connections

3.5mm Audio (Mic In) Pink	TE	1734152-5
3.5mm Audio (Line In) Light Blue	TE	1734152-6
3.5mm Audio (Line Out) Lime	TE	1734152-4
3.5mm Audio (Headphone) Black	TE	1734152-7

2.4.4 OLED

An Inteltronic/Wisechip UG-2832HSWEG04 OLED Display is used on the ZedBoard. This provides a 128x32 pixel, passive-matrix, monochrome display. The display size is 30mm x 11.5mm x 1.45mm.

Table 11 - OLED Connections

Pin Number	Symbol	Zynq Pin	Function
Power Supply			
7	VDD	U12	<i>Power Supply for Logic</i>
6	VSS	N/C	<i>Ground of OEL System</i>
15	VCC	N/C	<i>Power Supply for OEL Panel</i>
Driver			
13	IREF	N/C	<i>Current Reference for Brightness Adjustment</i>
14	VCOMH	N/C	<i>Voltage Output High Level for COM Signal</i>
DC/DC Converter			
5	VBAT	U11	<i>Power Supply for DC/DC Converter Circuit</i>
3 / 4 1 / 2	C1P / C1N C2P / C2N	N/C	<i>Positive Terminal of the Flying Inverting Capacitor Negative Terminal of the Flying Boost Capacitor</i>
Interface			
9	RES#	U9	<i>Power Reset for Controller and Driver</i>
8	CS#	N/C	<i>Chip Select – Pulled Down on Board</i>
10	D/C#	U10	<i>Data/Command Control</i>
11	SCLK	AB12	<i>Serial Clock Input Signal</i>
12	SDIN	AA12	<i>Serial Data Input Signal</i>

2.5 Clock sources

The Zynq-7000 AP SoC's PS subsystem uses a dedicated 33.3333 MHz clock source, IC18, Fox 767-33.333333-12, with series termination. The PS infrastructure can generate up to four PLL-based clocks for the PL system. An on-board 100 MHz oscillator, IC17, Fox 767-100-136, supplies the PL subsystem clock input on bank 13, pin Y9.

2.6 Reset Sources

2.6.1 Power-on Reset (PS_POR_B)

The Zynq PS supports external power-on reset signals. The power-on reset is the master reset of the entire chip. This signal resets every register in the device capable of being reset. ZedBoard drives this signal from a comparator that holds the system in reset until all power supplies are valid. Several other IC's on ZedBoard are reset by this signal as well.

2.6.2 Program Push Button Switch

A PROG push switch, BTN6, toggles Zynq PROG_B. This initiates reconfiguring the PL-subsection by the processor.

2.6.3 Processor Subsystem Reset

Power-on reset, labeled PS_RST/BTN7, erases all debug configurations. The external system reset allows the user to reset all of the functional logic within the device without disturbing the debug environment. For example, the previous break points set by the user remain valid after system reset. Due to security concerns, system reset erases all memory content within the PS, including the OCM. The PL is also reset in system reset. System reset does not re-sample the boot mode strapping pins.

2.7 User I/O

2.7.1 User Push Buttons

The ZedBoard provides 7 user GPIO push buttons to the Zynq-7000 AP SoC; five on the PL-side and two on the PS-side.

Pull-downs provide a known default state, pushing each button connects to Vcco.

Table 12 - Push Button Connections

Signal Name	Subsection	Zynq pin
BTNU	PL	T18
BTNR	PL	R18
BTND	PL	R16
BTNC	PL	P16
BTNL	PL	N15
PB1	PS	D13 (MIO 50)
PB2	PS	C10 (MIO 51)

2.7.2 User DIP Switches

The ZedBoard has eight user dip switches, SW0-SW7, providing user input. SPDT switches connect the I/O through a 10kΩ resistor to the VADJ voltage supply or GND.

Table 13 - DIP Switch Connections

Signal Name	Zynq pin
SW0	F22
SW1	G22
SW2	H22
SW3	F21
SW4	H19
SW5	H18
SW6	H17
SW7	M15

2.7.3 User LEDs

The ZedBoard has eight user LEDs, LD0 – LD7. A logic high from the Zynq-7000 AP SoC I/O causes the LED to turn on. LED's are sourced from 3.3V banks through 390Ω resistors.

Table 14 - LED Connections

Signal Name	Subsection	Zynq pin
LD0	PL	T22
LD1	PL	T21
LD2	PL	U22
LD3	PL	U21
LD4	PL	V22
LD5	PL	W22
LD6	PL	U19
LD7	PL	U14
LD9	PS	D5 (MIO7)

2.8 10/100/1000 Ethernet PHY

The ZedBoard implements a 10/100/1000 Ethernet port for network connection using a Marvell 88E1518 PHY. This part operates at 1.8V. The PHY connects to MIO Bank 1/501 (1.8V) and interfaces to the Zynq-7000 AP SoC via RGMII. The RJ-45 connector is a TE Connectivity 1840750-7 featuring integrated magnetics. The RJ-45 has two status indicator LEDs that indicate traffic and valid link state.

A high-level block diagram of one 10/100/1000 Ethernet interface is shown in the following figure.

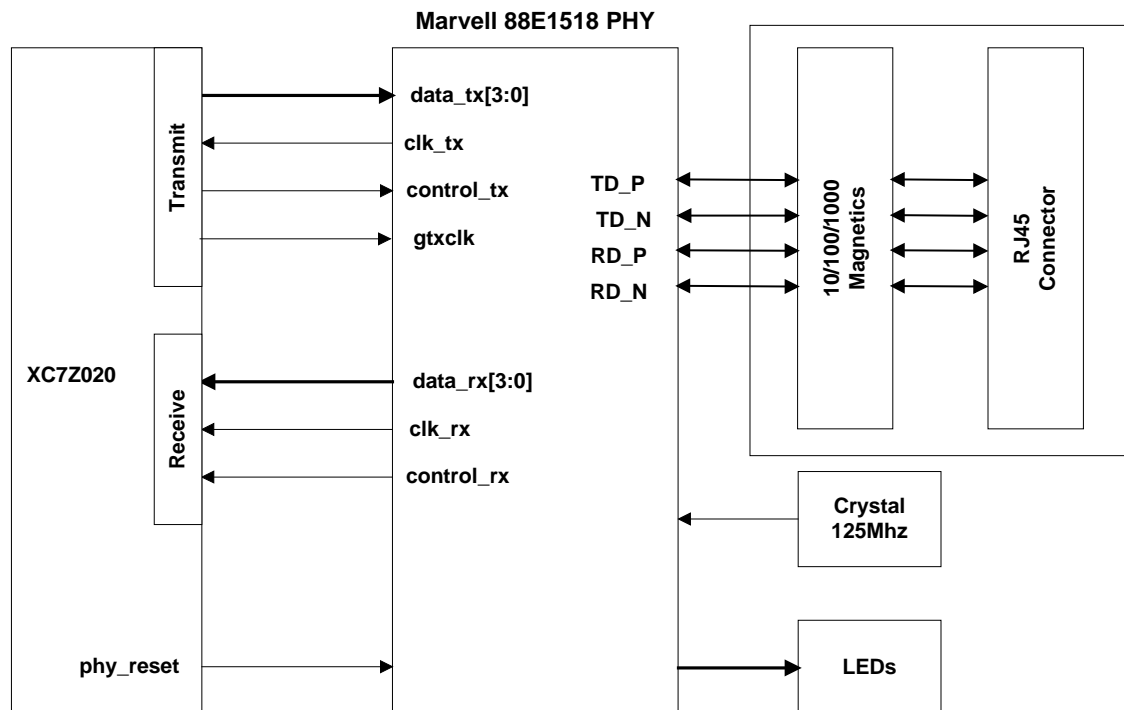

Figure 11 - 10/100/1000 Ethernet Interface

Zynq requires a voltage reference for RGMII interfaces. Thus PS_MIO_VREF, F8, is tied to 0.9V, half the bank voltage of MIO Bank 1/501.

Table 15 – Ethernet PHY Pin Assignment and Definitions

Signal Name	Description	Zynq pin	MIO	88E1510 pin
RX_CLK	Receive Clock	A14	16:27	40
RX_CTRL	Receive Control	D7		37
RXD[3:0]	Receive Data	RXD0: E11		38
		RXD1: B7		39
		RXD2: F12		41
		RXD3: A13		42
TX_CLK	Transmit Clock	D6		47
TX_CTRL	Transmit Control	F11		2
TXD[3:0]	Transmit Data	TXD0: E9		44
		TXD1: A7		45
		TXD2: E10	48	
		TXD3: A8	1	
MDIO	Management Data	C12	52:53	5
MDC	Management Clock	D10		4

The datasheet for the Marvell 88E1518 is not available publicly. An NDA is required for this information. Please contact your local Avnet or Marvell representative for assistance.

2.9 Expansion Headers

2.9.1 LPC FMC Connector

A single low-pin count (LPC) FMC slot is provided on the ZedBoard to support a large ecosystem of plug-in modules. The LPC FMC exposes 68 single-ended I/O, which can be configured as 34 differential pairs. The FMC interface spans over two PL I/O banks, banks 34 and 35. To meet the FMC spec, these banks are powered from an adjustable voltage set by jumper, J18. Selectable voltages include 1.8V, default, and 2.5V. It is also possible to set Vadj to 3.3V. Since 3.3V could potentially be the most damaging voltage setting for Vadj, this is not available with the default board hardware. To set Vadj to 3.3V, solder a short across the 3V3 pads at J18 or solder in an additional 1x2 header. The FMC pin out can be copied from the Master UCF, see ZedBoard.org.

WARNING: Before attaching a FMC Card, ensure the correct voltage is selected on jumper, J18. Failure to do so may result in damage to the FMC card and/or the ZedBoard.

Note, the following LPC FMC connections guidelines were followed:

§ **CLK_#_M2C**

- 50 ohm single-ended impedance
- Less than 10mil skew in P/N pair
- Connected to GC (Global Clock) preferential or MRCC (Multi-Region) if not available
- No length matching to any other feature

§ **LA bus**

- 50 ohm single-ended impedance
- Less than 10mil skew in P/N pair
- Less than 100mil length skew across all bits in a bus
 - No restriction between LA, HA or HB
- LA Bus 0:16 to be located in one bank
- LA Bus 17:33 to be located in one bank
- CC Pairs 0, 17 to be placed on MRCC pins
- CC Pairs 1, 18 to be placed on SRCC pins
 - HB_06_CC optional placed on clock pin if available

§ To conserve Zynq pins, GA[1:0] were removed and connected to GND.

2.9.2 Digilent Pmod™ Compatible Headers (2x6)

The ZedBoard has five Digilent Pmod™ compatible headers (2x6). These are right-angle, 0.1” female headers that include eight user I/O plus 3.3V and ground signals as show in the figure below.

Four Pmod connectors interface to the PL-side of the Zynq-7000 AP SoC. These will connect to Bank 13 (3.3V). One Pmod, JE1, connects to the PS-side on MIO pins [7,9-15] in MIO Bank 0/500 (3.3V). Uses for this Pmod include PJTAG access (MIO[10-13]) as well as nine other hardened MIO peripherals (SPI, GPIO, CAN, I2C, UART, SD, QSPI, Trace, Watchdog).

The four PL Pmod connectors are placed in adjacent pairs on the board edge such that the clearance between Pin 6 of header #1 and Pin 1 of header #2 is 10mm.

Two of the Pmods, JC1 and JD1, are aligned in a dual configuration and have their I/O routed differentially to support LVDS running at 525Mbps.

All Pmod data lines, 8 per connector, are protected with two 4-channel TE SESD1004Q4UG-0020-090.

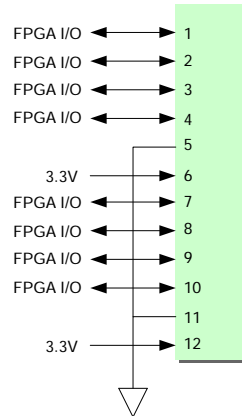

Figure 12 - Pmod Connections

A couple links to Pmod examples are provided:

- <http://www.em.avnet.com/en-us/design/drc/Pages/Digilent-PmodWiFi-802-11bgn-WiFi-Interface.aspx>
- <http://www.em.avnet.com/en-us/design/drc/Pages/Digilent-Pmod-RS232-Serial-Converter-and-Interface.aspx>

Table 16 - Pmod Connections

Pmod	Signal Name	Zynq pin	Pmod	Signal Name	Zynq pin
JA1	JA1	Y11	JB1	JB1	W12
	JA2	AA11		JB2	W11
	JA3	Y10		JB3	V10
	JA4	AA9		JB4	W8
	JA7	AB11		JB7	V12
	JA8	AB10		JB8	W10
	JA9	AB9		JB9	V9
	JA10	AA8		JB10	V8

Pmod	Signal Name	Zynq pin	Pmod	Signal Name	Zynq pin
JC1 Differential	JC1_N	AB6	JD1 Differential	JD1_N	W7
	JC1_P	AB7		JD1_P	V7
	JC2_N	AA4		JD2_N	V4
	JC2_P	Y4		JD2_P	V5
	JC3_N	T6		JD3_N	W5
	JC3_P	R6		JD3_P	W6
	JC4_N	U4		JD4_N	U5
	JC4_P	T4		JD4_P	U6

Pmod	Signal Name	Zynq pin
JE1 MIO Pmod	JE1	A6
	JE2	G7
	JE3	B4
	JE4	C5
	JE7	G6
	JE8	C4
	JE9	B6
	JE10	E6

2.9.3 Agile Mixed Signaling (AMS) Connector, J2

The XADC header provides analog connectivity for analog reference designs, including AMS daughter cards like Xilinx’s AMS Evaluation Card.

The analog header is placed close to the LPC FMC header as shown. Both analog and digital IO can be easily supported for a plug in card. This allows the analog header to be easily connected to the FMC card using a short ribbon cable as shown. The analog header can also be used “stand alone” to support the connection of external analog signals.

The pin out has been chosen to provide tightly coupled differential analog pairs on the ribbon cable and to also provide AGND isolation between channels. The plug in cards which will facilitate a number of reference designs have not yet been designed so this pin out must provide a reasonable degree of freedom while also keeping resource requirements as minimal as possible.

The ZedBoard AMS header is comparable with similar connectors on the Xilinx KC705 and ZC702 boards. Any AMS plug-in cards built for those boards should be compatible with ZedBoard as well.

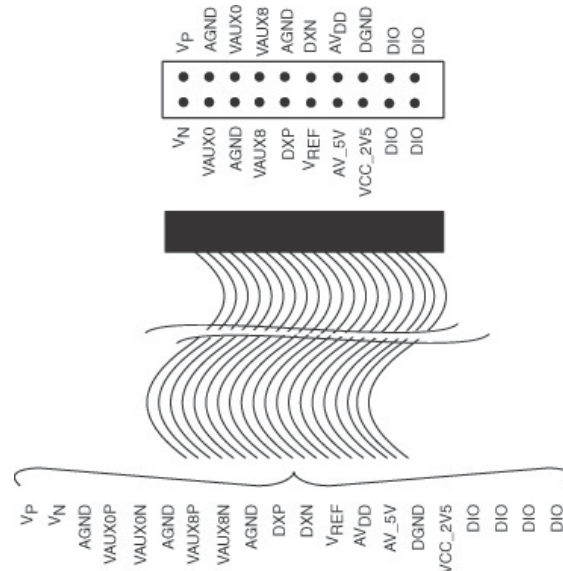

Figure 13 - Analog Header Pin out

The following anti-aliasing filters were used for the XADC inputs:

- V_P/V_N
- V_{AUX0P}/V_{AUX0N}
- V_{AUX8P}/V_{AUX8N}

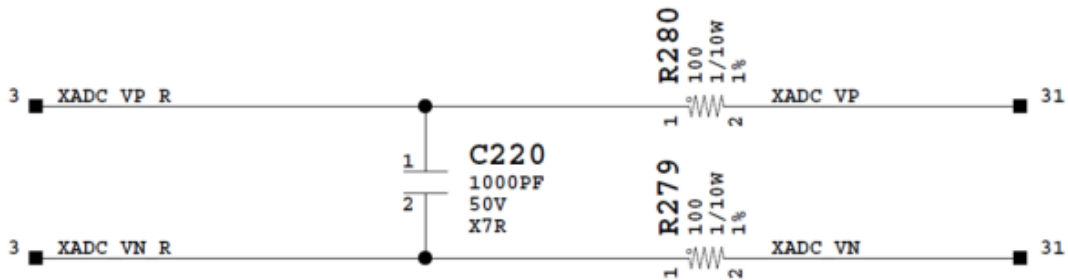

Figure 14 - Anti-Aliasing Filters for XADC Inputs

Table 17 - Analog Header Pin Out

Name	Description	Requirement	XADC Header	Zynq Pin
V_P/V_N	Two pins required. Dedicated pins on the 7 series package. This is the dedicated analog input channel for the ADC(s).	1V peak-to-peak input maximum	1 2	XADC-VN-R : M12 XADC-VP-R : L11
V_{AUX0P}/V_{AUX0N}	Two pins required. Auxiliary analog input channel 0. Two dedicated channels needed for simultaneous sampling applications. Should also support use as IO inputs by disconnection of anti-alias cap see	1V peak-to-peak input maximum	6 3	XADC-AD0N-R : E16 XADC-AD0P-R : F16
V_{AUX8P}/V_{AUX8N}	Two pins required. Auxiliary analog input channel 8. Two dedicated channels needed for simultaneous sampling applications. Should also support use as IO inputs by disconnection of anti-alias cap see	1V peak-to-peak input maximum	7 8	XADC-AD8N-R : D17 XADC-AD8P-R : D16
DXP/DXN	Two pins required. Access to thermal Diode		12 9	XADC-DXN : N12 XADC-DXP : N11
AGND	Three pins required. Analog ground reference GNDADC. Analog channel isolation		4 5 10	
VCCADC	One pin. This is the analog 1.8V supply for XADC.	1.8V \pm 5% @150mA max	14	
V_{REF}	One pin. This is the 1.25V reference from the board.	1.25V \pm 0.2% 50ppm/ $^{\circ}$ C @5mA max	11	
AV_5V	Filtered 5V supply from board.	5V \pm 5% @150mA max	13	
GPIO	General Purpose I/O	Voltage set by Vadj	G0: 18 G1: 17 G2: 20 G3: 19	H15 R15 K15 J15
Vadj	Adjustable Voltage, set by J18	1.8V, 2.5V, 3.3V		

2.10 Configuration Modes

Zynq-7000 AP SoC devices use a multi-stage boot process that supports both non-secure and secure boot (note that secure boot is not supported for CES silicon.) The PS is the master of the boot and configuration process. The following table shows the Zynq configuration modes. Upon reset, the device mode pins are read to determine the primary boot device to be used: NOR, NAND, Quad-SPI, SD Card or JTAG.

By default, the ZedBoard uses the SD Card configuration mode. The boot mode pins are MIO[8:2] and are used as follows:

- MIO[2]/Boot_Mode[3] sets the JTAG mode
- MIO[5:3]/Boot_Mode[2:0] select the boot mode
- MIO[6]/Boot_Mode[4] enables the internal PLL
- MIO[8:7]/Vmode[1:0] are used to configure the I/O bank voltages, however these are fixed on ZedBoard and not configurable

The ZedBoard provides jumpers for MIO[6:2]. These are 1x3 jumpers connected as shown below. All mode pins can be pulled high or low through a 20 K Ω resistor.

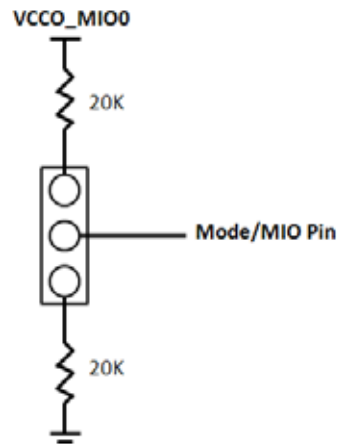

Figure 15 - Configuration Mode Jumpers

These jumpers allow users to change the mode options, including using cascaded JTAG configuration as well as using the internal PLL.

As noted above, the VMODE pins are strapped permanently to set Bank 500 and 501 voltages to 3.3V and 1.8V. These are not jumper selectable.

The PS boot mode selections are shown in the table below, default setting highlighted in yellow:

Table 18 – ZedBoard Configuration Modes

Xilinx TRMà	MIO[6]	MIO[5]	MIO[4]	MIO[3]	MIO[2]
	Boot_Mode[4]	Boot_Mode[0]	Boot_Mode[2]	Boot_Mode[1]	Boot_Mode[3]
JTAG Mode					
Cascaded JTAG					0
Independent JTAG					1
Boot Devices					
JTAG		0	0	0	
Quad-SPI		1	0	0	
SD Card		1	1	0	
PLL Mode					
PLL Used	0				
PLL Bypassed	1				
Bank Voltages					
MIO Bank 500			3.3V		
MIO Bank 501			1.8V		

Expected configuration time using a 50MB/s QSPI flash is 250ms.

PUDC_B is pulled high on ZedBoard but can be pulled low via JP5. This active-low input enables internal pull-ups during configuration on all SelectIO pins

A push button labeled “PROG” is connected to the Zynq PROG pin, T11, and pulled up. Pushing the button connects PROG to ground. Pushing this button will clear the PL configuration memory, effectively resetting the entire PL subsection. The PS is responsible for reconfiguring the PL. Zynq will not automatically reconfigure the PL as in standard FPGAs. The user software application must reprogram the PL. An interrupt will indicate a change in the devcfg.INT_STS register and the configuration pin status can be read from the devcfg.STATUS register. When configuration is complete, a blue LED, LD12, labeled DONE, will light.

2.10.1 JTAG

As an alternative to using the onboard USB-JTAG interface, the ZedBoard provides traditional Platform Cable JTAG connector, J15, for use with Xilinx Platform Cables and Digilent JTAG HS1 Programming Cables. The JTAG Chain is constructed as follows:

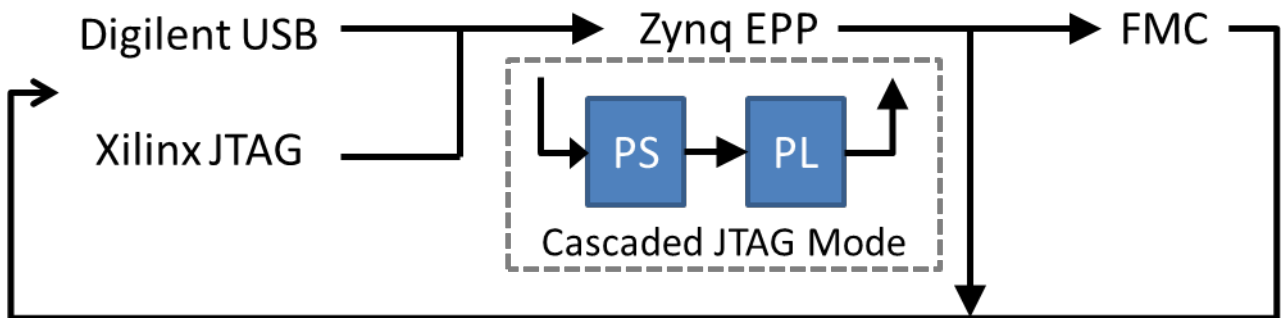

Figure 16 - ZedBoard JTAG Chain

ZedBoard automatically adds the FMC into the JTAG chain when an FMC card is plugged into the board via the FMC-PRSENT signal.

2.11 Power

2.11.1 Primary Power Input

The board's primary input is through a 12V barrel jack. A compatible AC/DC converter will have a 2.5mm inner diameter, 5.5mm outer diameter, center positive connection.

The total power budget is based on 4A from an AC/DC wall wart supply. This rail is protected with a TE [0603SFF600F/24-2](#).

A 10mΩ, 1W current sense resistor exists in series with the 12V input power supply. Header J21 straddles this resistor to measure the voltage across this resistor for calculating ZedBoard power. Power is the measured voltage squared divided by the 10mΩ resistance.

2.11.2 On/Off Switch

ZedBoard includes an On/Off switch, SW8, to gate 12V. . When SW8 is in the OFF position, 12V is disconnected from the board.

2.11.3 Regulators

The following Maxim power solution provides the power rails of the ZedBoard.

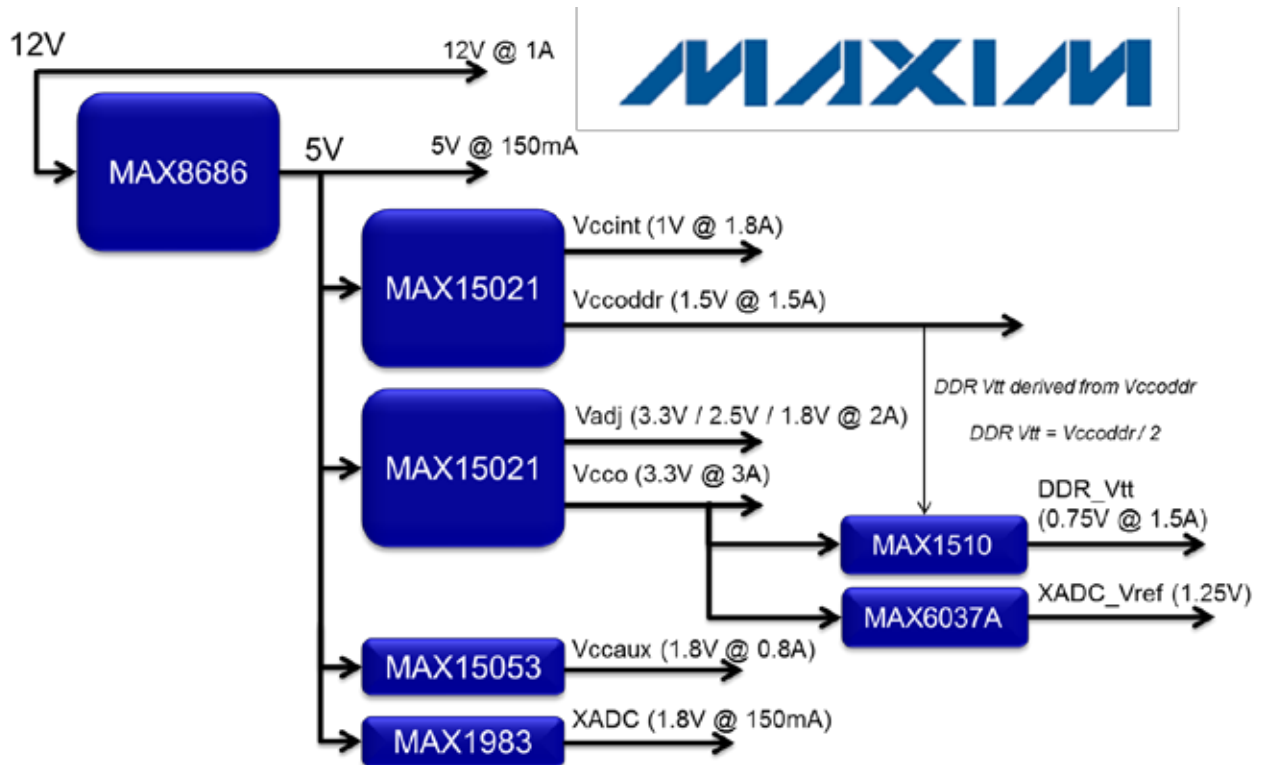

Figure 17 - Maxim Power Solution

The table below shows the minimum required voltage rails, currents, and tolerances.

Table 19 - TPS65708 Connections

Voltage (V)	Current (A)	Tolerance
1.0 (Vccint)	1.3	5.00%
1.5 (Vccoddr)	1.5	5.00%
1.8 (Vccaux)	0.8	5.00%
1.8, 2.5, 3.3 (jumper adjustable, 2.5V default) (Vadj)	2	5.00%
3.3 (Vcco/FMC/Pmod)	3	5.00%
1.8 (analog) (Vccadc)	0.15	5.00%
1.25 reference (Vrefp)	0.005	0.2%, 50ppm/°C
0.75 (DDR3 Vtt)	1.5	5.00%
5.0 (Filtered for XADC)	0.15	5.00%

2.11.4 Sequencing

Sequencing for the power supplies follows the recommendations for the Zynq device. PS and PL INT and AUX supplies are tied together on the ZedBoard platform to create a low cost design. The following diagram illustrates the supply sequencing:

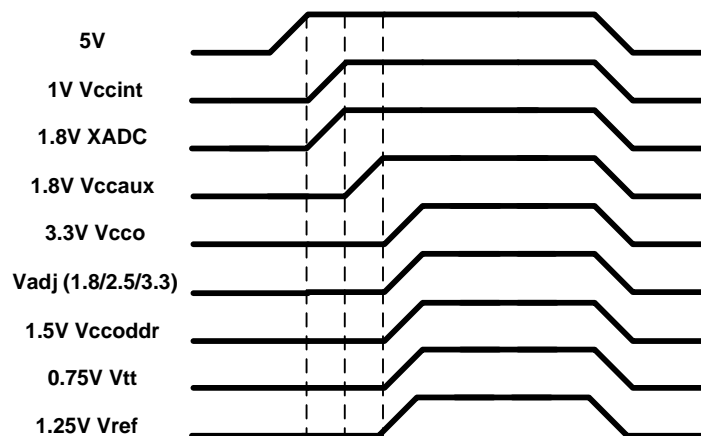

Figure 18 - Power Sequencing

In addition to the sequencing, a power on reset circuit is used to hold the board in reset until all power supplies have reached their regulation point.

2.11.5 Power Good LED

A green status LED, LD13, indicates when power is good on the board. Power Good is wired with the Resets and PROG to prevent operation of the board when power is not good.

2.11.6 Power Estimation

The Power estimation chart is shown below.

Table 20 – Current Usage Estimations, in mA

Feature	Part Number	MFG	Bank	1.0V	1.5V	1.8V	Vadj	3.3V
Zynq-7000 AP SoC PS	Z7020-CLG484	Xilinx		600	250	150		150
Zynq-7000 AP SoC PL	Z7020-CLG484	Xilinx		1200		300		50
DDR3	MT41K128M16HA-15E:D	Micron	VCCO_DDR		425			
DDR3 Termination					360			
QSPI Flash	S25FL256S Vcc	Spansion						100
QSPI Flash	S25FL256S Vio	Spansion	VCCO_MIO0					2
10/100/1000 PHY	88E1518 internal	Marvell		72		63		50
10/100/1000 PHY	88E1518 Vddo	Marvell	VCCO_MIO1			27		
USB 2.0 OTG PHY	TUSB1210	TI	VCCO_MIO1			30		30
HDMI Transmitter	ADV7511	ADI				181		0
Audio Codec	ADAU1761	ADI						58
OLED	UG-2832HSWEG04	Univision						28
Clock	F4100	Fox						40
USB JTAG	SMT1	Digilent						110
UART to USB	CY7C64225	Cypress	VCCO_MIO1					26
SD Card			VCCO_MIO1					100
PS User LED (green)			VCCO_MIO0					5
PL User LEDs (green) x8								40
PS User PB x2			VCCO_MIO0					0
PL User PBs x5								0
PL User Slide Switches x8								0
Status LEDs (amber) x4?								20
DONE LED (blue)								5
PS Pmod	TE 5-534206-6	TE	VCCO_MIO0					3000
PL Pmod #1	TE 5-534206-6	TE						
PL Pmod #2	TE 5-534206-6	TE						
PL Pmod #3	TE 5-534206-6	TE						
PL Pmod #4	TE 5-534206-6	TE						
FMC-LPC							2000	
Total				1872	1035	751	2000	3814
				1.0	1.5	1.8	2.5	3.3

2.11.7 Testing

The power circuitry has been tested to verify compliance with the Zynq power requirements, such as:

- Tolerance
 - 1.0V Vccint à 0.95 to 1.05V
 - Vccaux à +/- 5%
 - Vcco à +/-5%
- Ramp time
 - 0.20 to 50ms
 - In-rush current must be controlled so the power circuitry is not overloaded at start-up
- Monotonicity
 - No negative dips in Vccint or Vccaux power-up ramps
- Sequencing
 - Verify sequencing responds as expected based on design
- Refer to Zynq Datasheet for the latest requirements

2.11.8 Probes

Two ground test point are available on the board, J3 and J4. This allows easy access to attach ground leads of two scope probes to the board without having to locate GND pins on a header.

3 Zynq-7000 AP SoC Banks

The following figure and table show Zynq CLG484 I/O bank assignments on the Zynq board.

	1	2	3	4	5	6	7	8	9	10	11	12	13	14	15	16	17	18	19	20	21	22	
A	500	500	500	500		500	501	501	501		501	501	501	501		35	35	35	35		35	35	A
B	502	502		500	500	500	501		501	501	501	501		501	35	35	35		35	35	35	35	B
C		502	502	500	500		501	501	501		501	501	501	35		35	35	35	35		35		C
D	502	502	502		500	501	501	501		501	501	501	501		35	35	35	35		35	35	35	D
E	502		502	500	500	500		501	501	501	501		501	501	35	35		35	35	35	35		E
F	502	502	502	502		500	500	501	501		501	501	501	501		35	35	35	35		35	35	F
G	502	502		502	502	500	500						501		35	35	35		35	35	35	35	G
H		502	502	502	502		502								34		35	35	35	35		35	H
J	502	502	502		502	502	502								34	34	34	34		34	34	34	J
K	502		502	502	502	502									34	34		34	34	34	34		K
L	502	502	502	502		502	502								34	34	34	34		34	34		L
M	502	502		502	502	502	502								34	34	34		34	34	34	34	M
N		502	502	502	502		502								34		34	34	34	34		34	N
P	502	502	502		502	502	502								34	34	34	34		34	34	34	P
R	502		502	502	502	13	13								34	34		34	34	34	34		R
T	502	502	502	13		13									34	34	34	34		33	33		T
U	502	502		13	13	13	13		13	13	13	13		33	33	33	33		33	33	33	33	U
V		502	502	13	13		13	13	13	13		13	33	33	33		33	33	33	33		33	V
W	502	502	502		13	13	13	13		13	13	13	33		33	33	33	33		33	33	33	W
Y	502		502	13	13	13		13	13	13	13		33	33	33	33		33	33	33	33		Y
AA	502	502	502	13		13	13	13	13		13	13	33	33		33	33	33	33		33	33	AA
AB	13	13		13	13	13	13		13	13	13	13		33	33	33	33		33	33	33	33	AB

Figure 19 - Zynq I/O Banks

3.1 Zynq-7000 AP SoC Bank Voltages

Table 21 - Zynq Bank Voltage Assignments

PS-Side	
Bank	Voltage (default)
MIO Bank 0/500	3.3V
MIO Bank 1/501	1.8V
DDR	1.5V
PL-Side	
Bank0	3.3V
Bank 13	3.3V
Bank 33	3.3V
Bank 34	Vadj (2.5V)
Bank 35	Vadj (2.5V)

Note: Banks 34 and 35 are powered from an adjustable voltage rail. Jumper, J18, selects this voltage. Selectable voltages include 1.8V, 2.5V and 3.3V. The 3.3V jumper was intentionally unpopulated on ZedBoard as these banks primarily connect to the FMC interface and many FMC cards are only 1.8V and 2.5V compatible. Connecting 3.3V to these cards can damage them, so leaving this jumper unpopulated reduces the risk of damaging FMC cards.

4 Jumper Settings

Table 22 - Jumper Settings

Ref Designator	Description	Default Setting	Function
JP1	Microphone Input Bias	Open – No Electret Microphone	Short to enable Bias Voltage for Electret Microphone. Right Channel only.
JP2	Vbus 5V Enable	Open – 5V Disconnected	Short to enable 5V output to USB OTG Connector, J13, for either Host or OTG modes.
JP3	USB Vbus Capacitor Setting	Open – Device Mode	Short for Host mode (>120uF). Open for Device or OTG modes (4.7uF).
JP4	CFGBVS Select	Not Populated	Pre-configuration I/O standard type for the dedicated configuration bank 0. Vcco_0 is 3.3V, Connected to 3.3V through a 10K resistor. This jumper connects to GND and should NOT be used.
JP5	PUDC Select	Not Populated	Active Low input enables internal pull-ups during configuration on all SelectIO pins. Connected to Vadj through 10K resistor.
JP6	PS_MIO0 Pull-Down	Short	Install for SD Card boot on CES silicon.
JP7	Boot_Mode[3]/MIO[2]	GND – Cascaded JTAG	JTAG Mode. GND cascades PS and PL JTAG chains. VCC makes JTAG chains independent.
JP8 JP9 JP10	Boot_Mode[0]/MIO[3] Boot_Mode[1]/MIO[4] Boot_Mode[2]/MIO[5]	110 – SD Card	Boot Device Select See Zynq Configuration Modes
JP11	Boot_Mode[4]/MIO[6]	GND – PLL Used	PLL Select. GND uses PS PLLs. VCC bypasses internal PS PLLs
JP12	XADC Ferrite Bead Disable	Open	Short bypasses XADC-GND ferrite bead connection to board GND.
JP13	JTAG PS-RST	Open	Short connects JTAG PROG-RST to PS Reset.
J18	Vadj Select	1.8V	Selects Vadj (1.8V, 2.5V, or 3.3V)

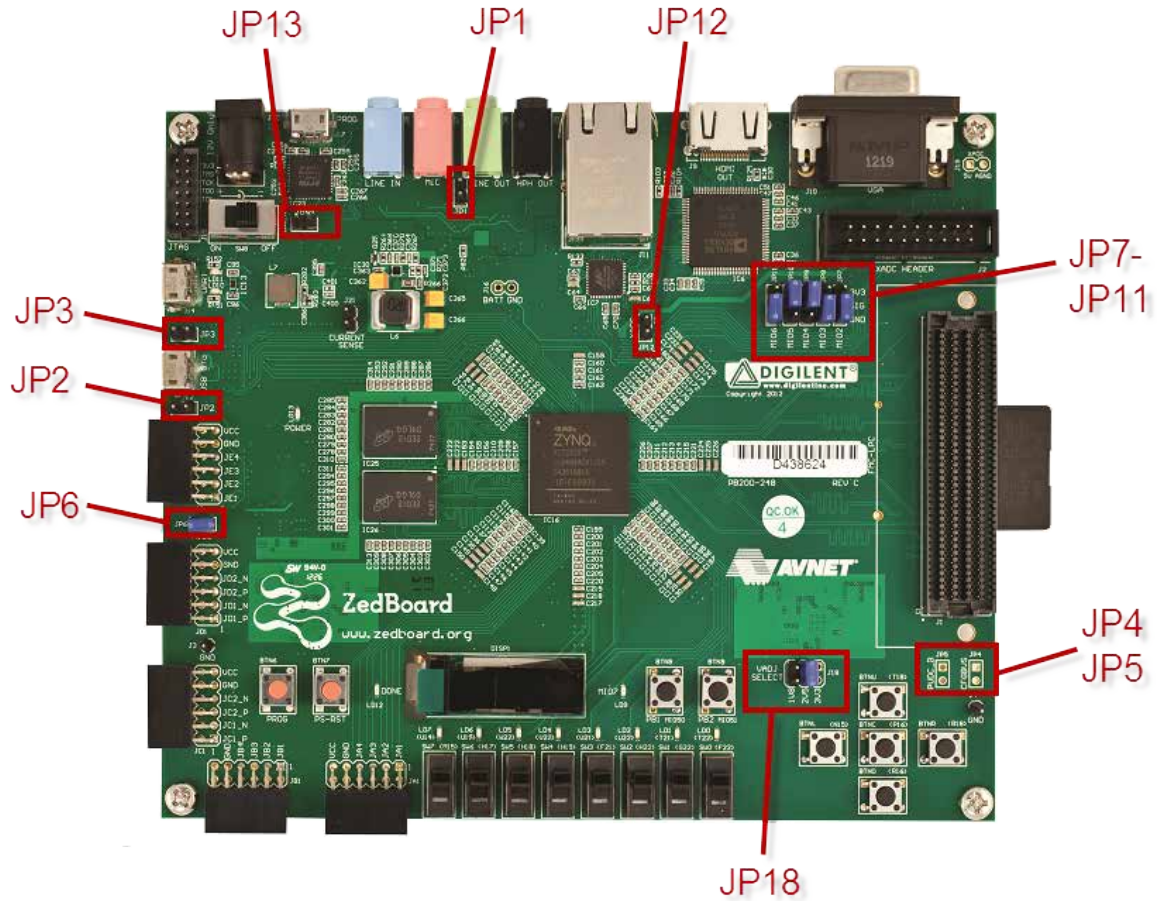

Figure 20 - ZedBoard Jumper Map

5 Mechanical

The ZedBoard measures 6.3"x6.3".

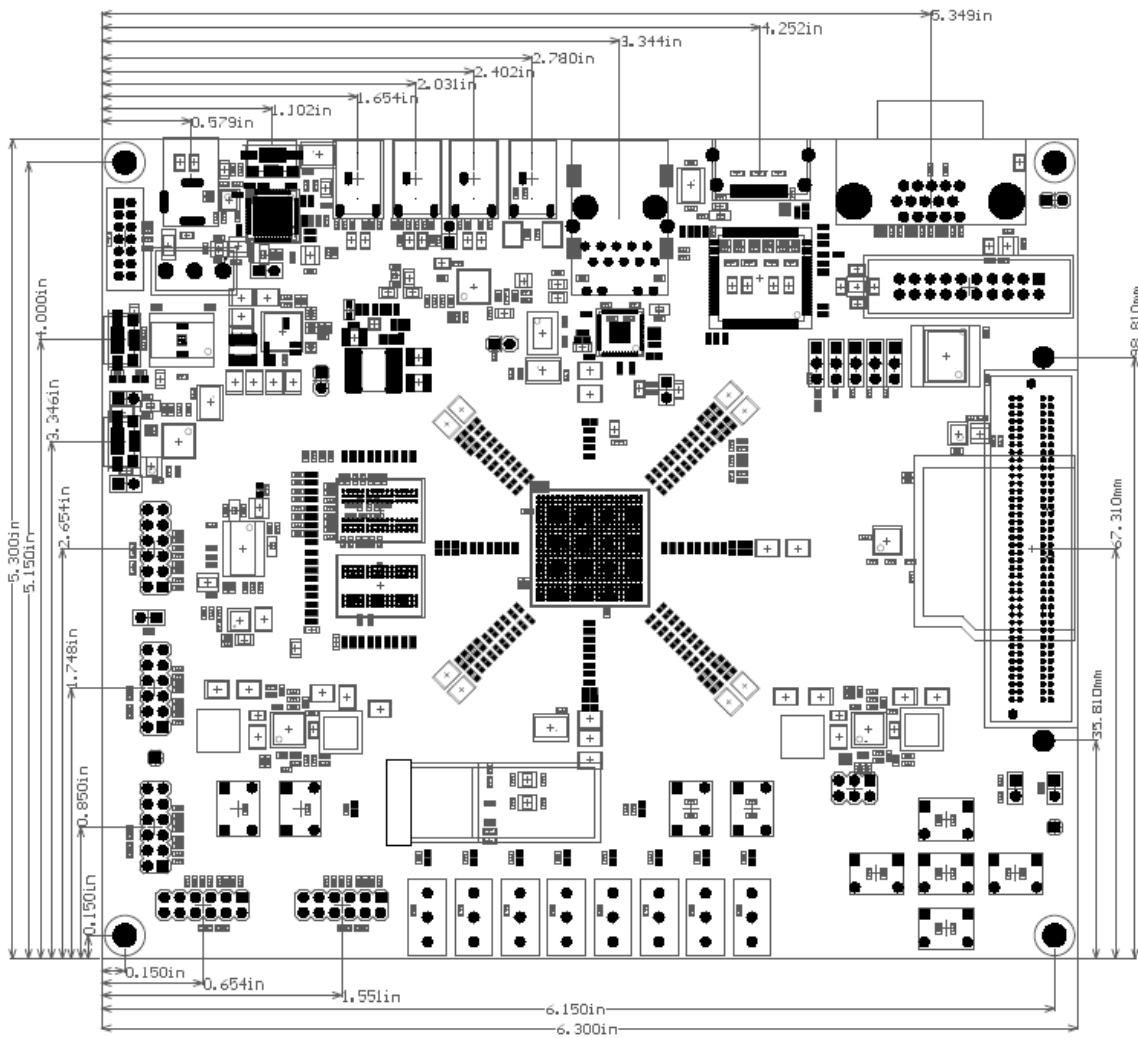

Figure 21 - ZedBoard Mechanical

Revision History

Rev date	Rev #	Reason for change
8/1/12	1.0	Initial ZedBoard User's Guide
8/2/12	1.1	Mapped Configuration Mode Table to match ZedBoard layout
8/14/12	1.2	Added MIO Pins and Peripheral Tables; Updated Reset Section; Updated Block Diagram
8/15/12	1.3	Updated Part Package numbering; Matched Xilinx Trademarks
8/30/12	1.4	Updated Board Images to Rev. C.1; Updated DDR3 section
9/4/12	1.5	Corrected package information in ZedBoard Block Diagram (fig. 1); Added note regarding connecting multiple Pmods
9/5/12	1.6	Fixed error in Pmod Pinout Table
1/17/13	1.7	Added TI USB OTG PHY design advisory notice
1/18/13	1.8	Added LD9 to docs; Updated Default Jumper Table; Updated Configuration Modes Table
1/29/13	1.9	Replaced RJ-45 184808-7 (obsolete) with 1840750-7