

EE 330

Lecture 7

- Propagation Delay
- Stick Diagrams
- Technology Files
 - Design Rules

Photo courtesy of the director of the National Institute of Health (NIH)



As a courtesy to fellow classmates, TAs, and the instructor

Wearing of masks during lectures and in the laboratories for this course would be appreciated irrespective of vaccination status

MOS Transistor

Qualitative Discussion of n-channel Operation

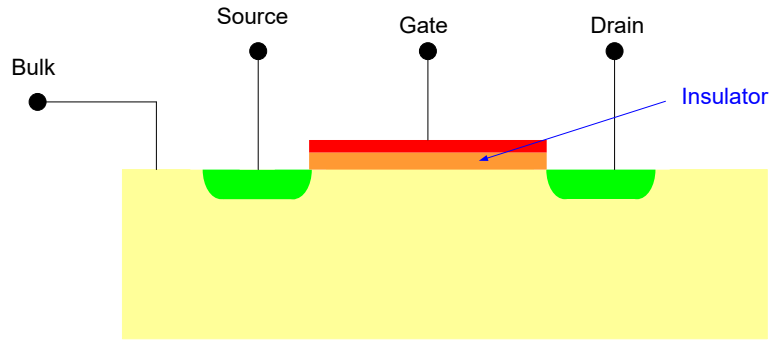

n-channel MOSFET

For V_{GS} small

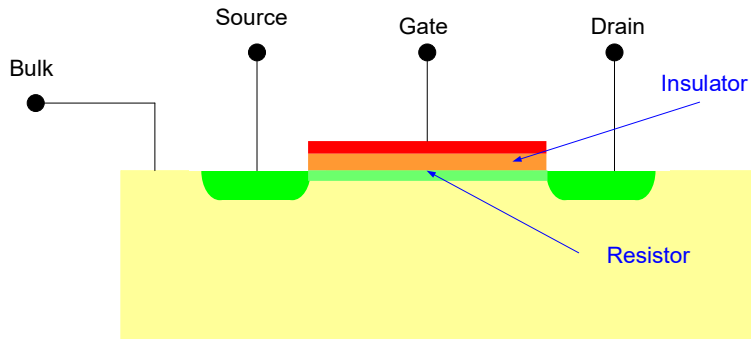

n-channel MOSFET

For V_{GS} large

- Region under gate termed the “channel”
- When “resistor” is electrically created, region where it resides in channel is termed an “inversion region”

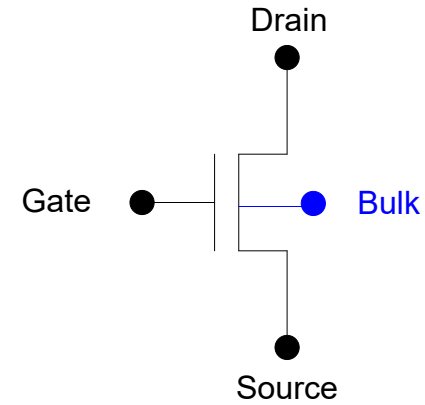

MOSFET actually 4-terminal device

Review from Last Time

MOS Transistor

Qualitative Discussion of n-channel Operation

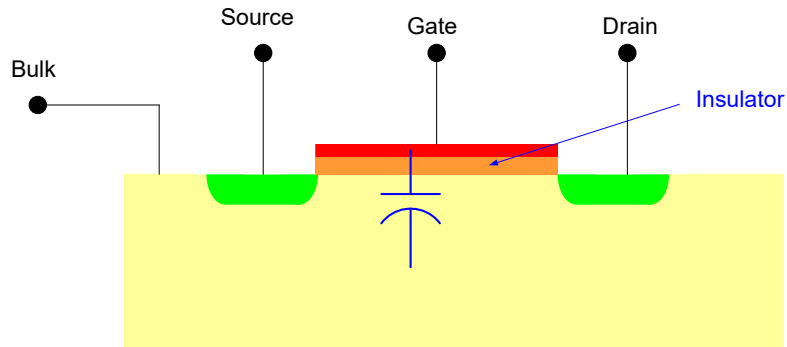

n-channel MOSFET

For V_{GS} small

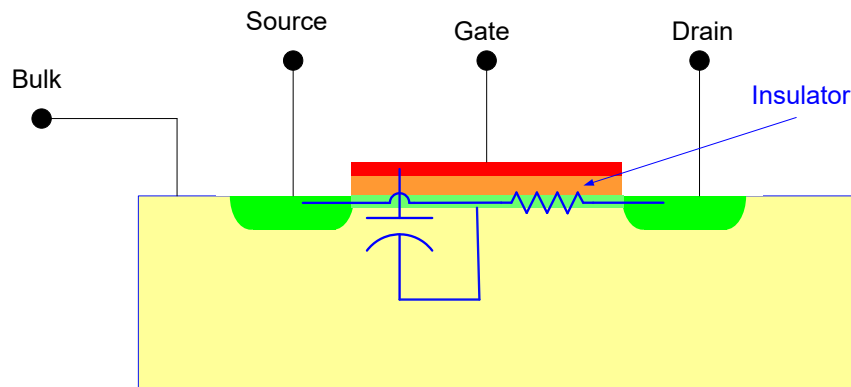

n-channel MOSFET

For V_{GS} large

- Electrically created inversion layer forms a “thin “film” resistor
- Capacitance from gate to channel region is distributed
- Lumped capacitance much easier to work with

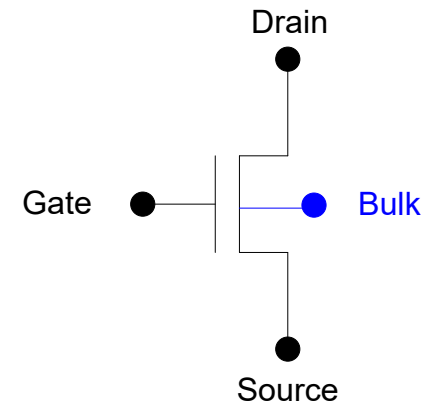

Review from Last Time

MOS Transistor

Qualitative Discussion of p-channel Operation

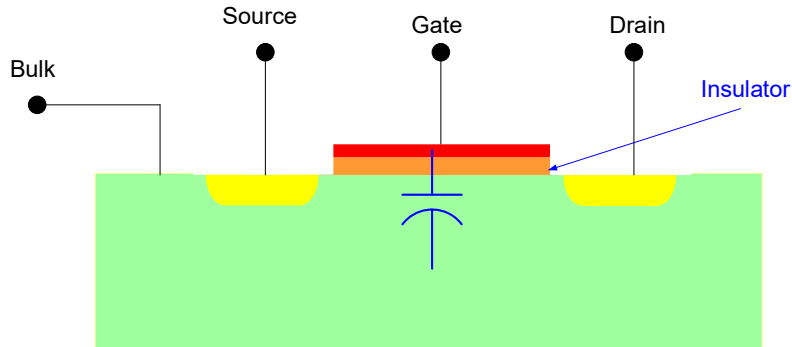

p-channel MOSFET

For $|V_{GS}|$ small

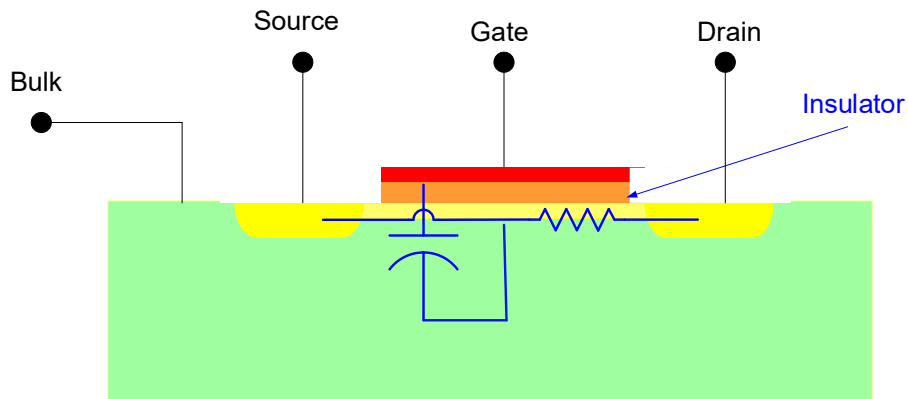

p-channel MOSFET

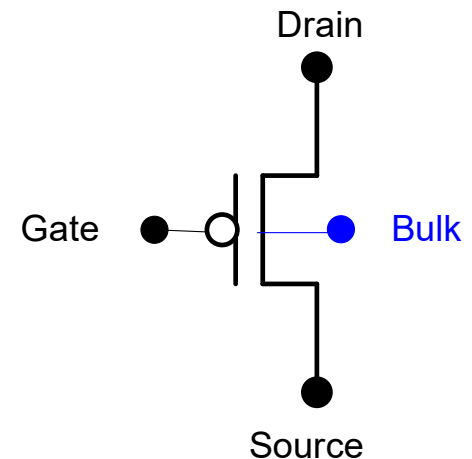

For $|V_{GS}|$ large

- Electrically created inversion layer forms a “thin “film” resistor
- Capacitance from gate to channel region is distributed
- Lumped capacitance much easier to work with

Review from Last Time

Improved Switch-Level Model

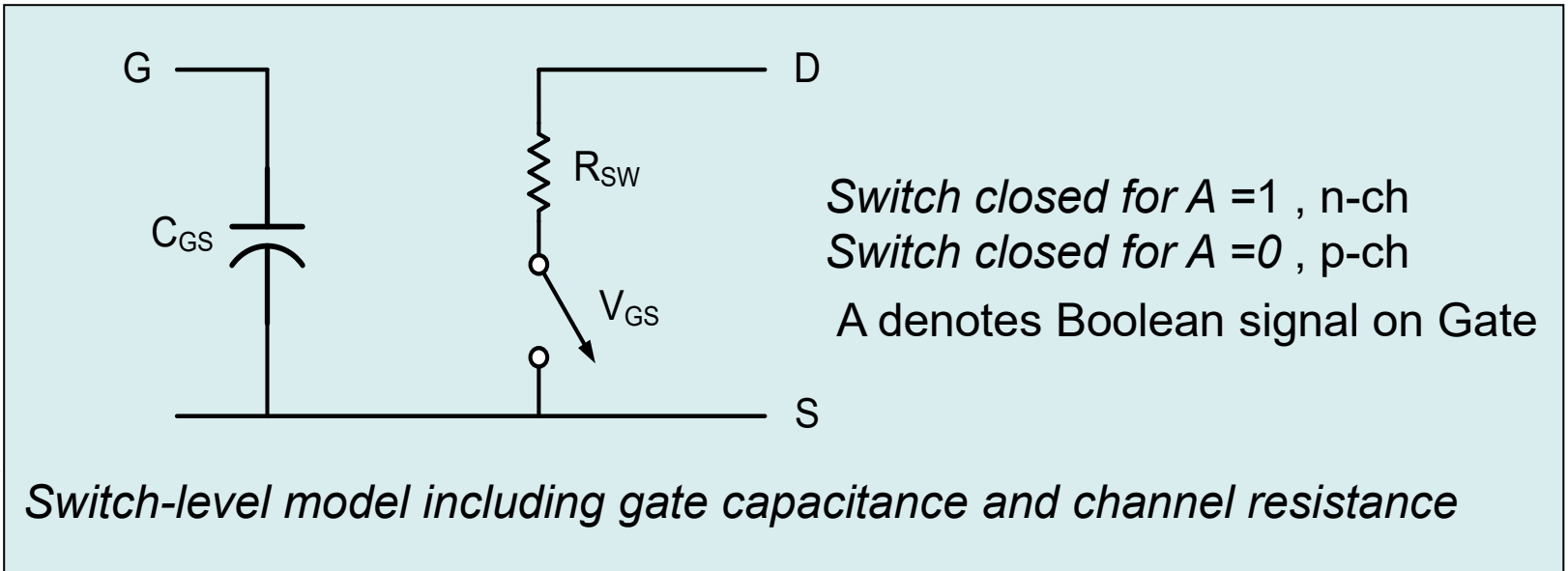
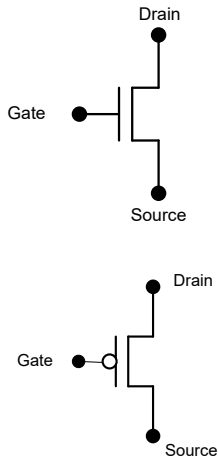

C_{GS} and R_{SW} dependent upon device sizes and process

For minimum-sized devices in a 0.5 μ process with $V_{DD}=5V$

$$\mathbf{C_{GS} \cong 1.5fF} \quad \mathbf{R_{sw} \cong \left. \begin{array}{l} 2K\Omega \text{ n-channel} \\ 6K\Omega \text{ p-channel} \end{array} \right\}}$$

Considerable emphasis will be placed upon device sizing to manage C_{GS} and R_{SW}

Review from Last Time

Is a capacitor of 1.5fF small enough to be neglected?

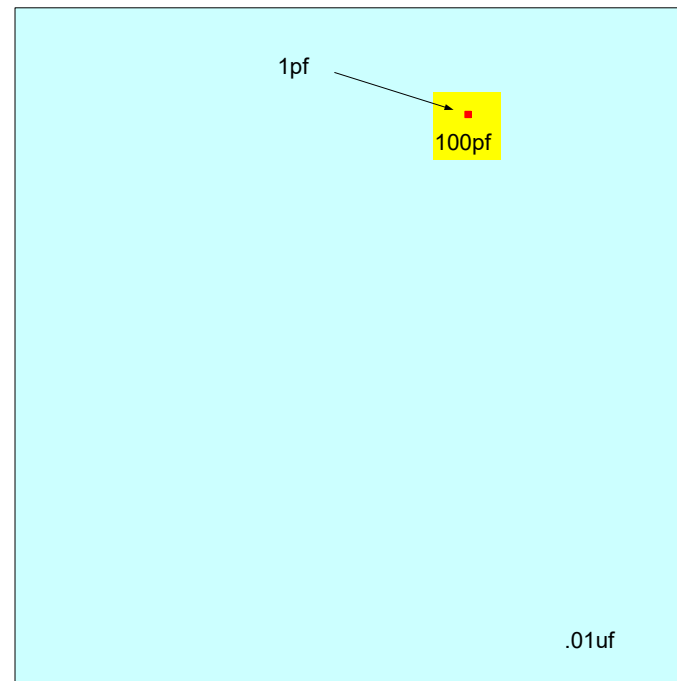

From EE 201 Parts Kit

Capacitors (Farads)		
100p	3	
470p	3	
0.001u	3	2
0.0047u	3	2
0.01u	3	
0.047u	3	
0.1u	3	1
0.47u	3	
1u	3	
10u	3	
100u	3	

Area allocations shown to relative scale:

Review from Last Time

Is a capacitor of 1.5fF small enough to be neglected?

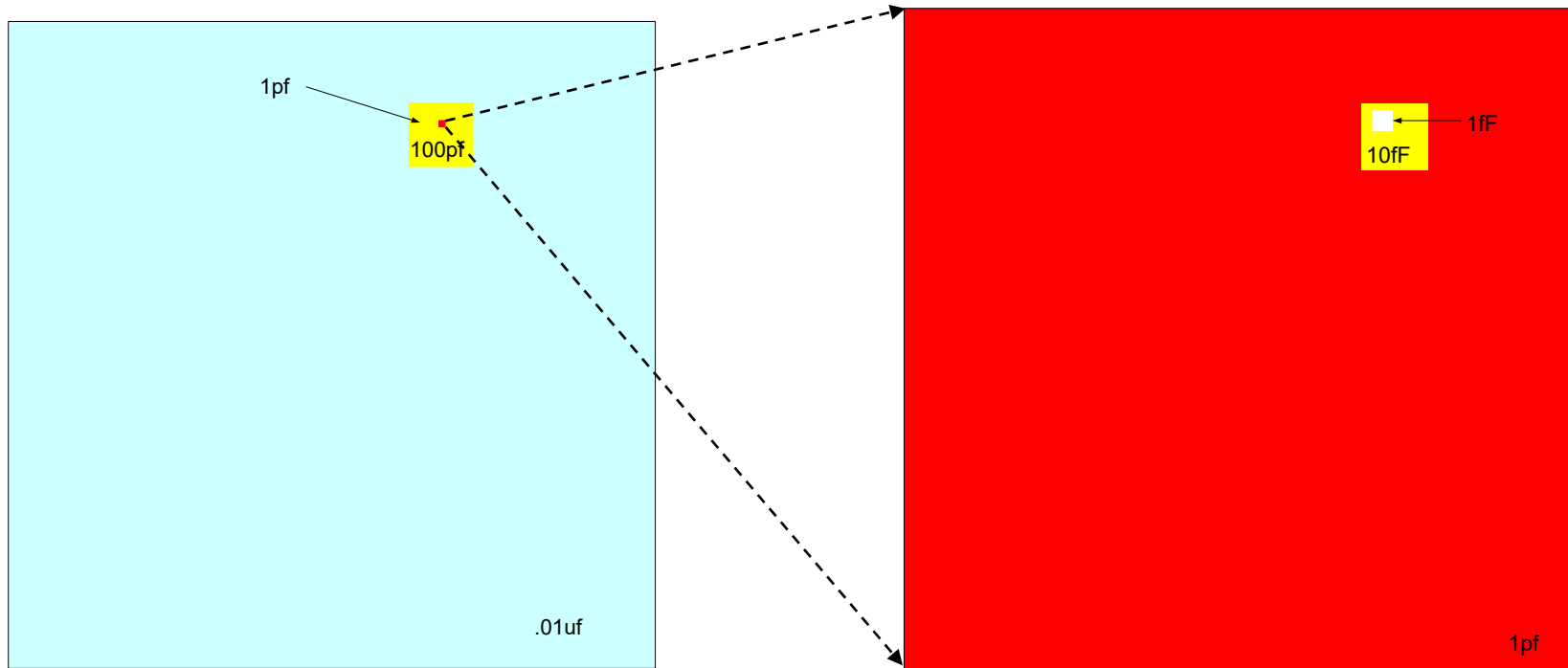

Area allocations shown to relative scale:

- **Not enough information at this point to determine whether this very small capacitance can be neglected**
- **Will answer this important question later**

Review from Last Time

Model Summary (for n-channel)

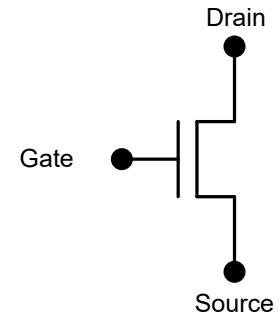

1. Switch-Level model

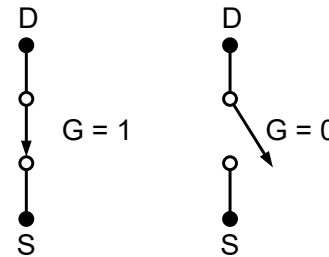

2. Improved switch-level model

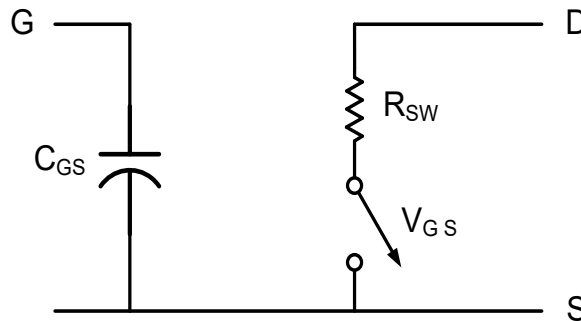

Switch closed for $V_{GS} = \text{large}$
Switch open for $V_{GS} = \text{small}$

Other models will be developed later

Review from Last Time

Model Summary (for p-channel)

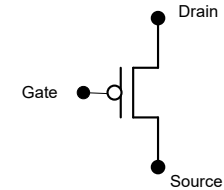

1. Switch-Level model

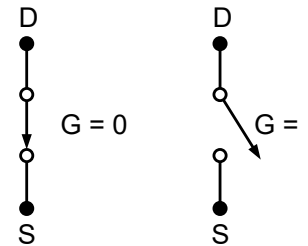

2. Improved switch-level model

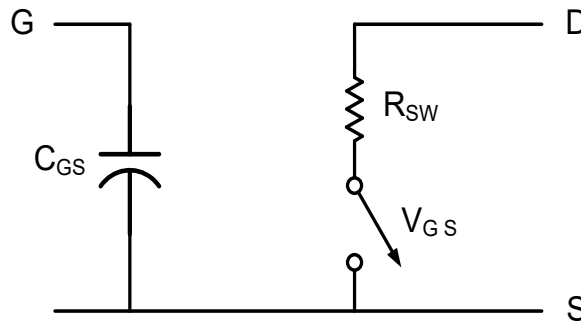

Switch closed for $|V_{GS}| = \text{large}$
Switch open for $|V_{GS}| = \text{small}$

Other models will be developed later

Propagation Delay

Example

What are t_{HL} and t_{LH} ?

Assume $V_{DD}=5V$

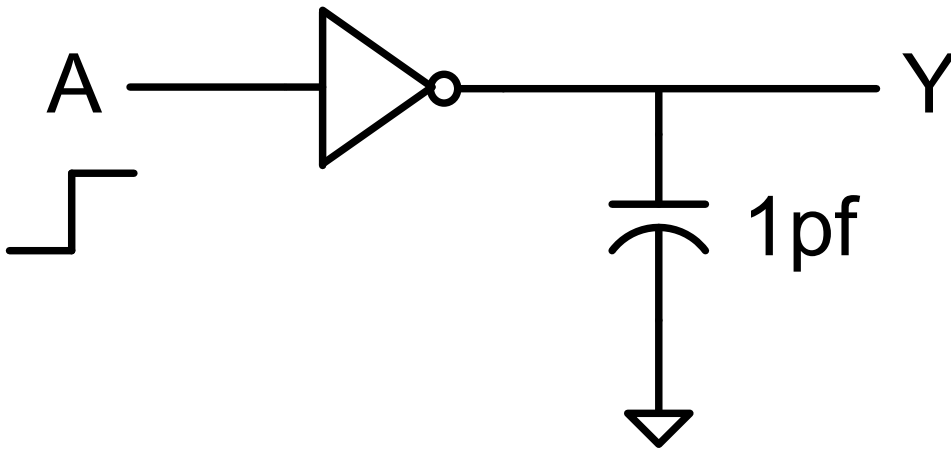

With basic switch level model ?

With improved switch level model ?

Example

Inverter with basic switch-level model

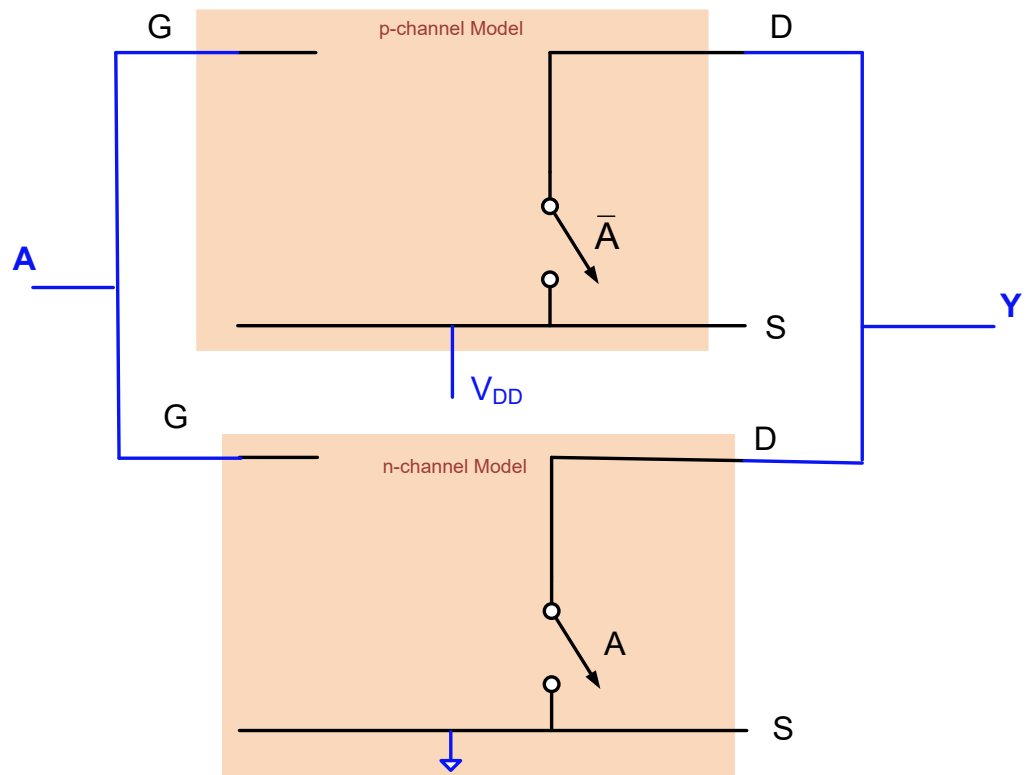

Example *What are t_{HL} and t_{LH} at output?*

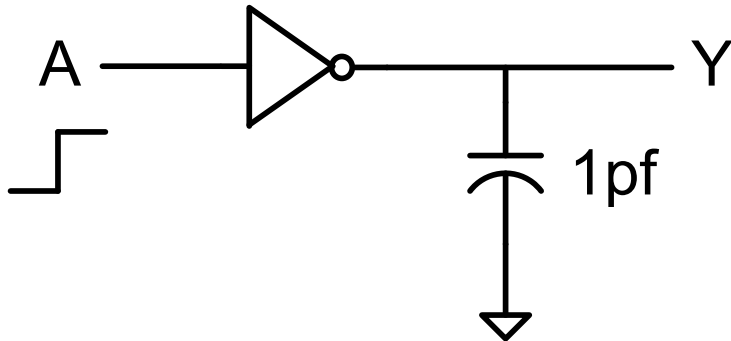

Assume ideal step at A input

With basic switch level model

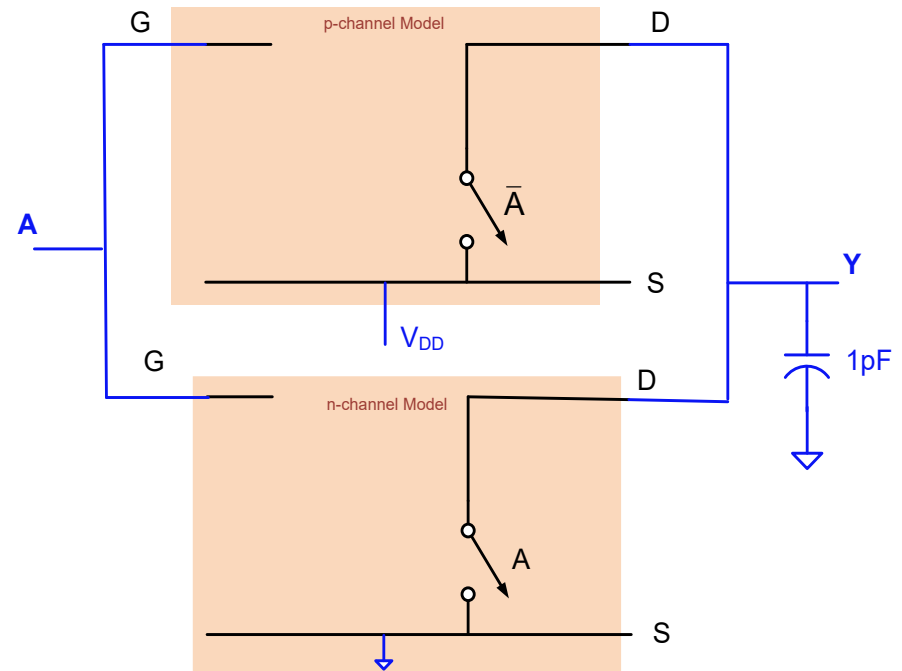
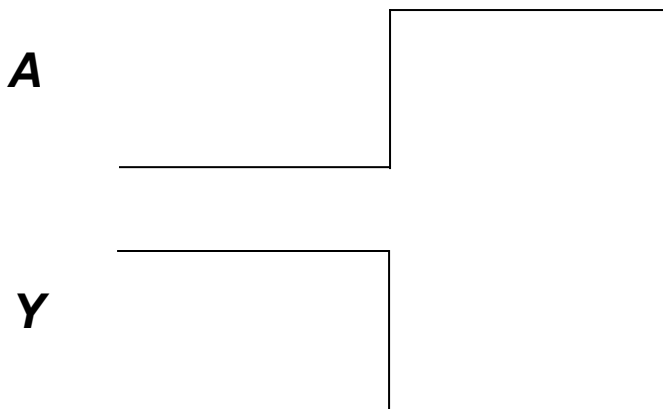

$$t_{HL} = t_{LH} = 0$$

Example (cont)

With simple switch-level model $t_{HL}=t_{LH}=0$

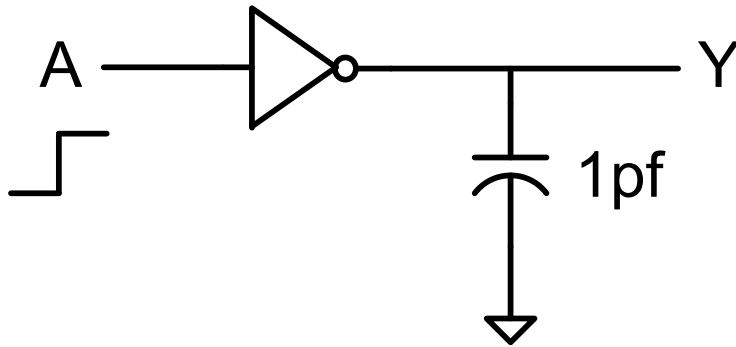

With improved model ?

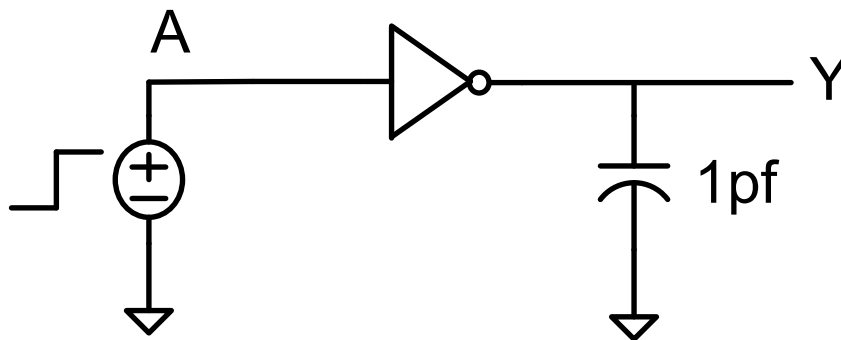

Inverter Model?

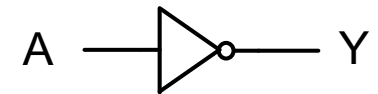

Example (cont)

Inverter with improved model

Inverter Model

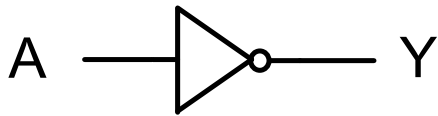

Inverter with Improved Model

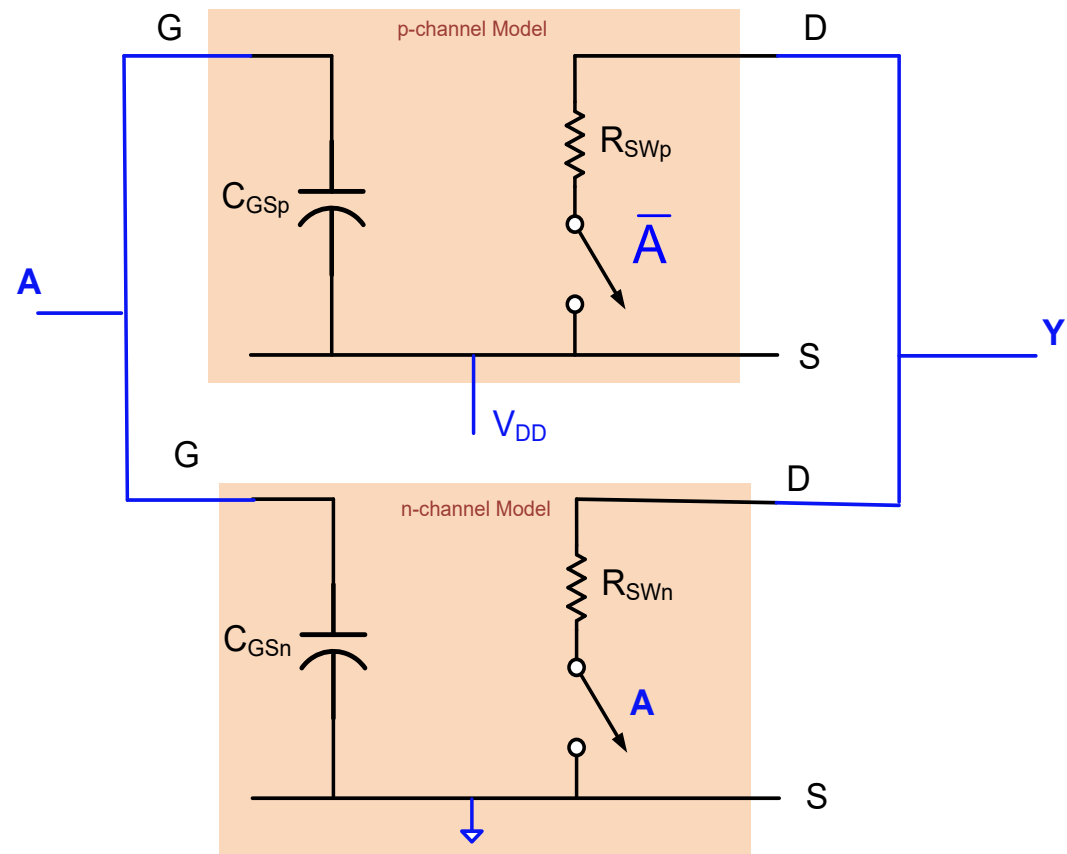

Example (cont)

With improved model $t_{HL}=?$

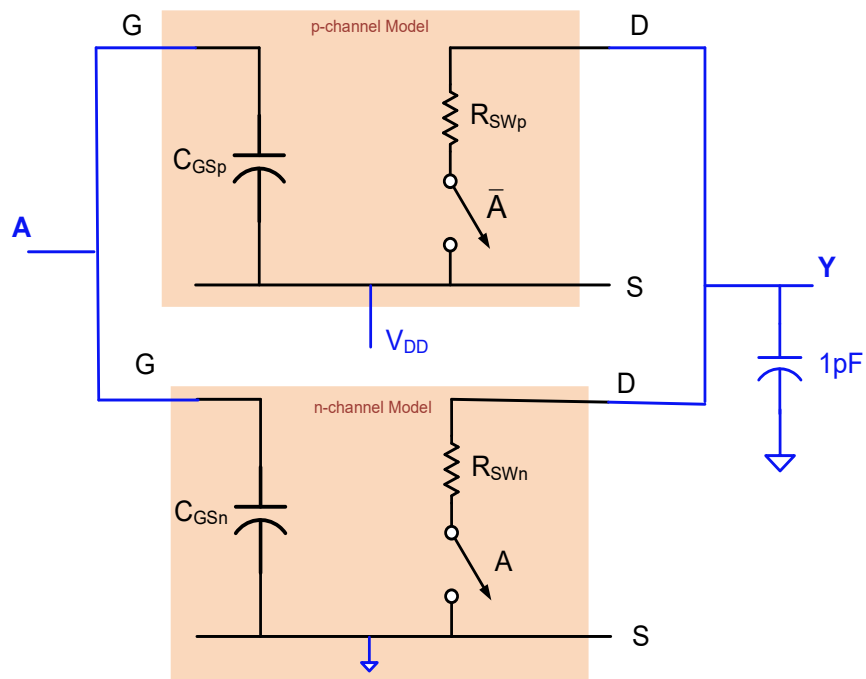
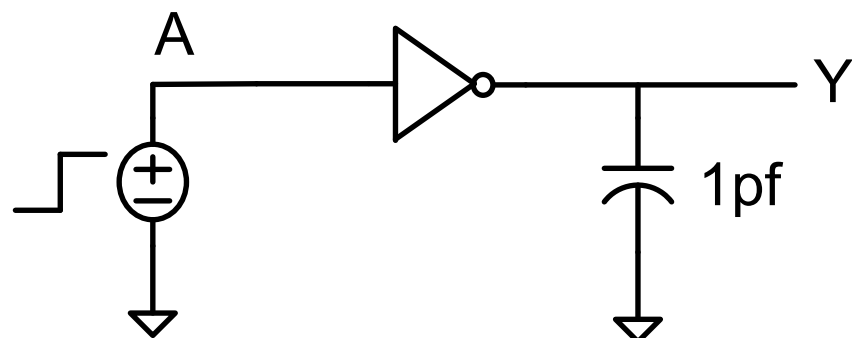

To initiate a HL output transition, assume Y has been in the high state for a long time and lower switch closes at time $t=0$

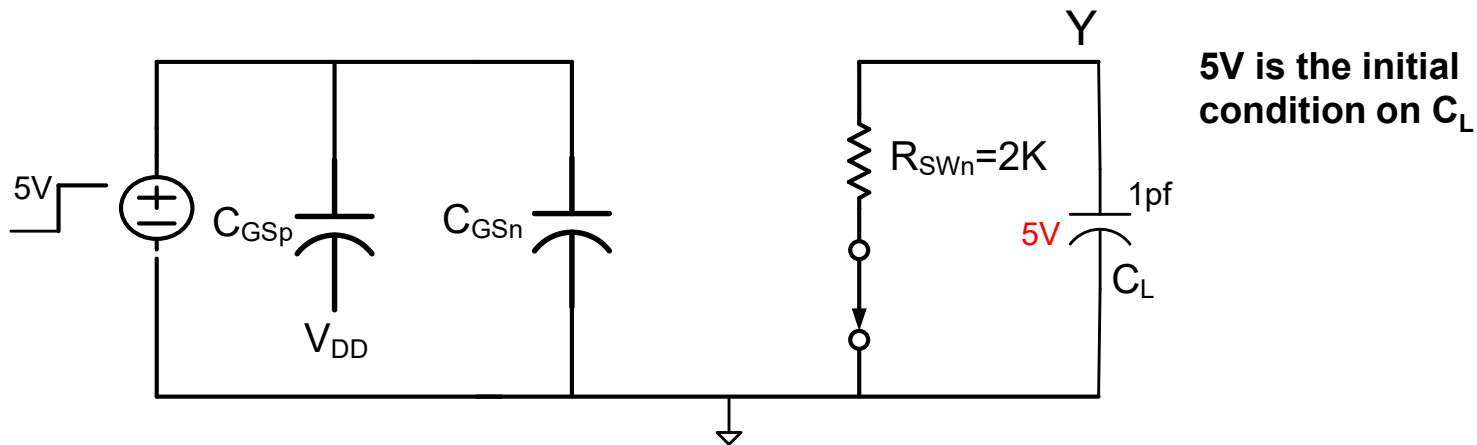

5V is the initial condition on C_L

Example (cont)

With improved model

$$t_{HL}=?$$

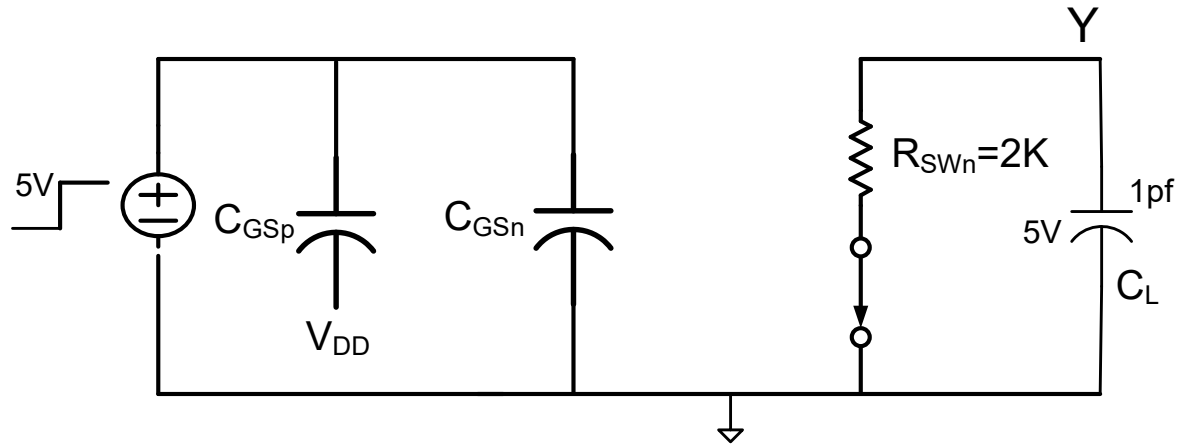

Recognize circuit as a first-order RC network

Recall: Step response of any first-order network with LHP pole can be written as

$$y(t) = F + (I - F)e^{-\frac{t}{\tau}}$$

where F is the final value, I is the initial value and τ is the time constant of the circuit

(from Chapter 7 of Nilsson and Riedel)

For the circuit above, $F=0$, $I=5$ and $\tau = R_{SWn} C_L$

Example (cont)

With improved model

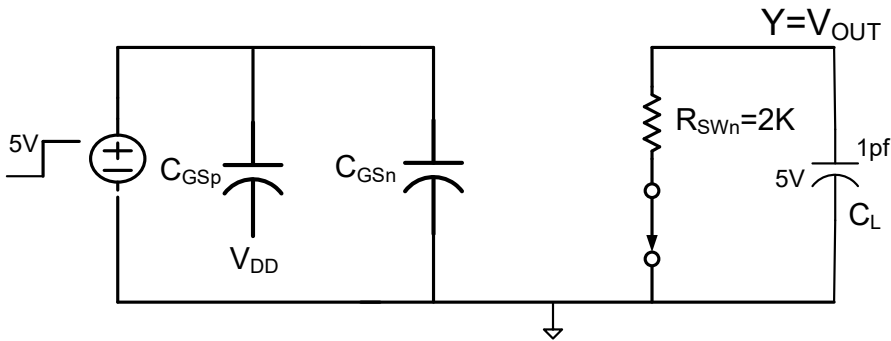

$$t_{HL}=?$$

$$V_{OUT}(t) = F + (I - F)e^{-\frac{t}{\tau}}$$

$$V_{OUT}(t) = 5e^{-\frac{t}{\tau}}$$

$$\tau = R_{SWn} C_L$$

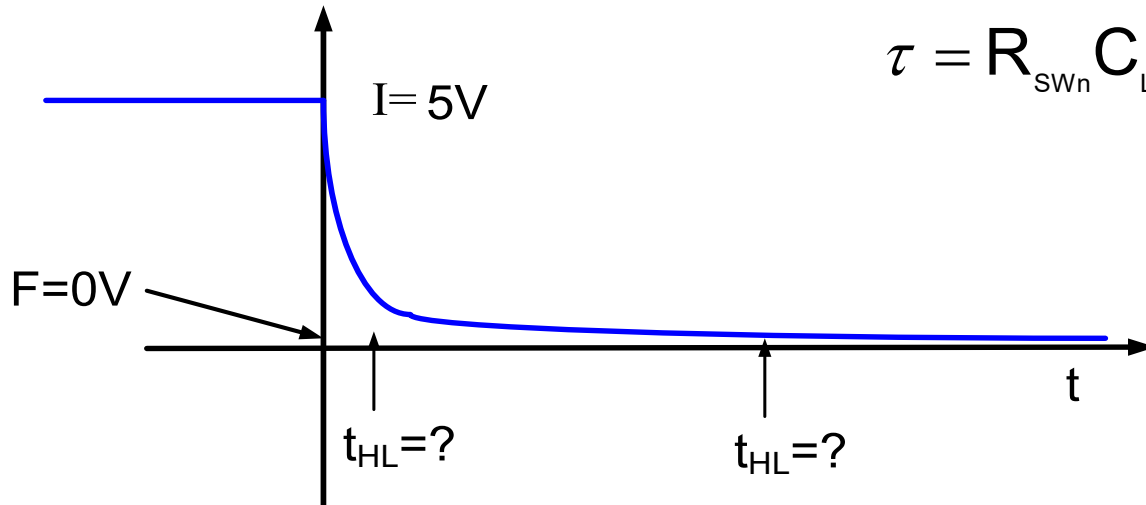

how is t_{HL} defined?

Example (cont)

$t_{HL}=?$

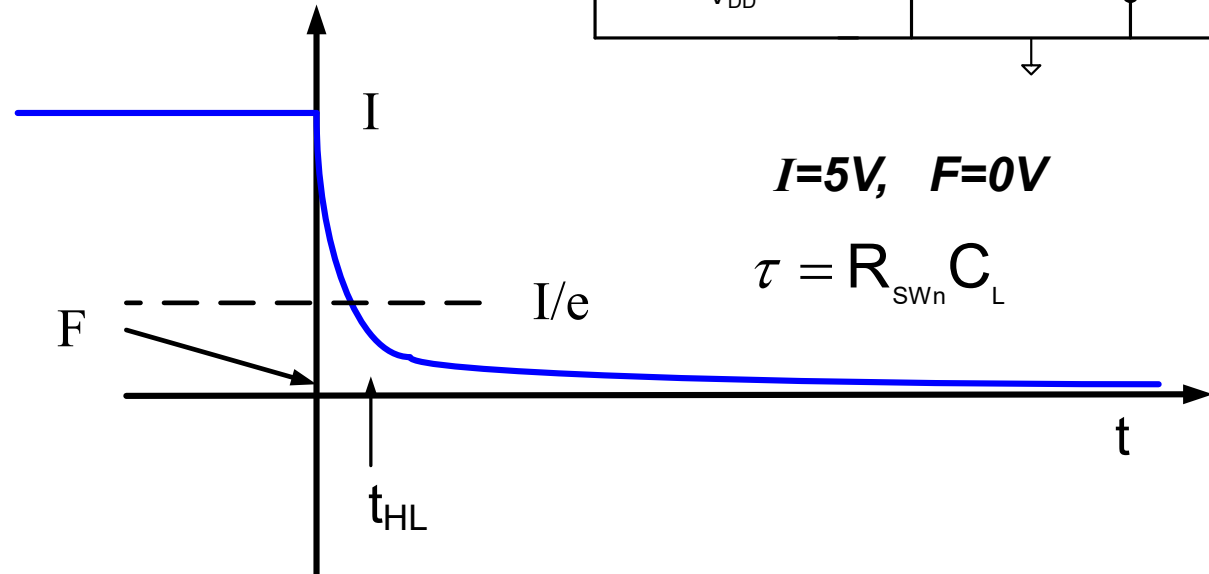
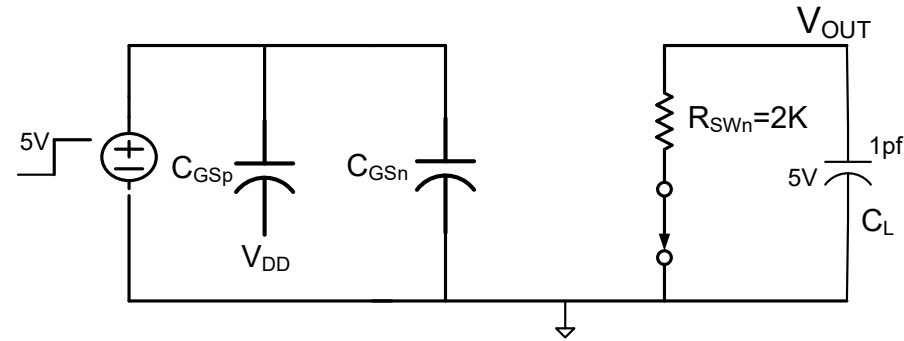

Define t_{HL} to be the time taken for output to drop to I/e

$$V_{OUT}(t) = F + (I - F)e^{-\frac{t}{\tau}} \quad \longrightarrow \quad \frac{I}{e} = F + (I - F)e^{-\frac{t_{HL}}{\tau}}$$

Is this simply a mathematical definition or does it have some practical significance?

t_{HL} as defined here has proven useful at analytically predicting response time of circuits

Example (cont)

With improved model

$$\frac{I}{e} = F + (I - F)e^{-\frac{t_{HL}}{\tau}}$$

$$\frac{I}{e} = Ie^{-\frac{t_{HL}}{\tau}}$$

$$\frac{1}{e} = e^{-\frac{t_{HL}}{\tau}}$$

$$t_{HL} = \tau$$



$$t_{HL} = R_{SWn} C_L$$

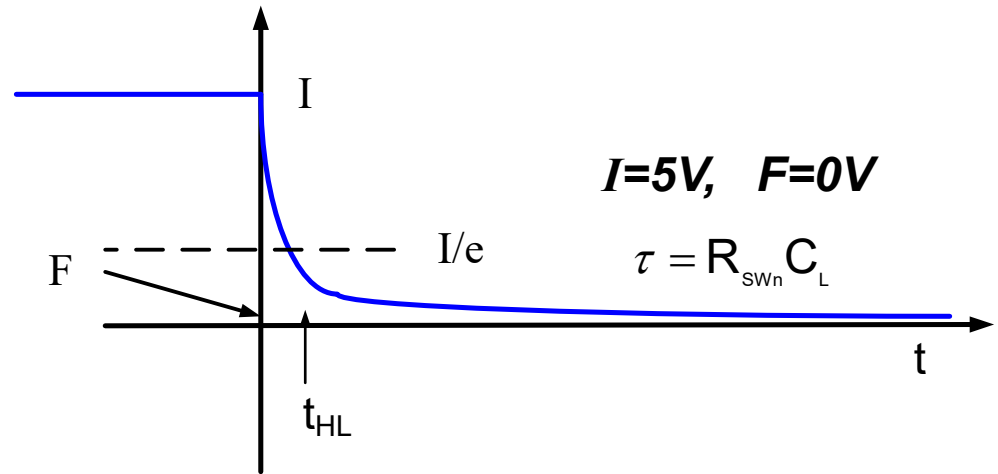

Both experimental results and accurate computer simulations show that this reasonably accurately predicts how quickly following stages recognize that a logic transition has taken place !!

Example (cont)

With improved model $t_{LH}=?$

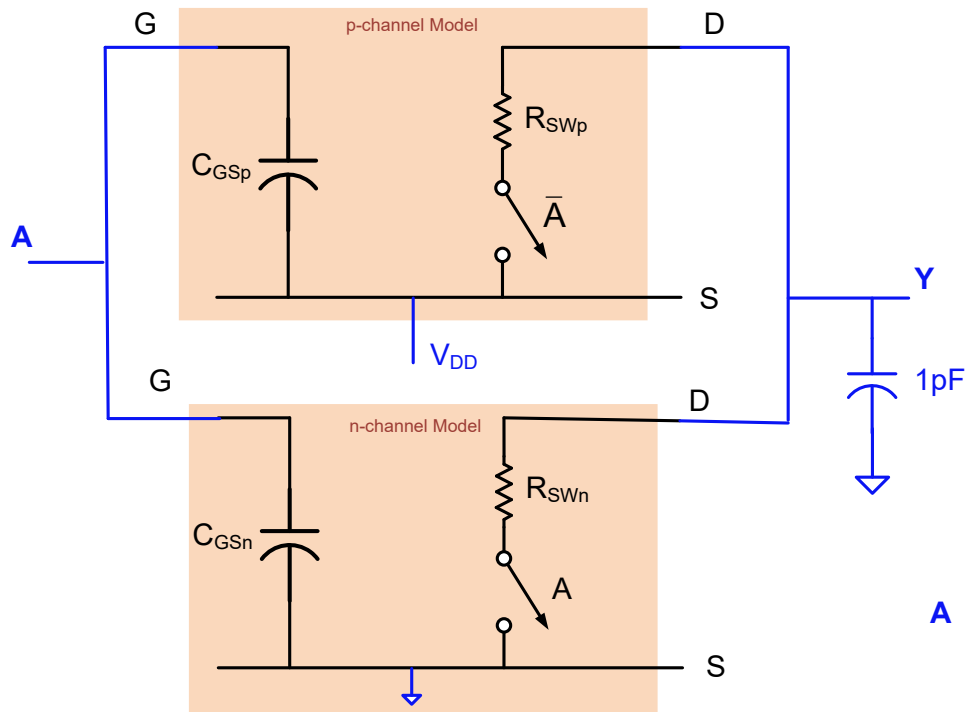
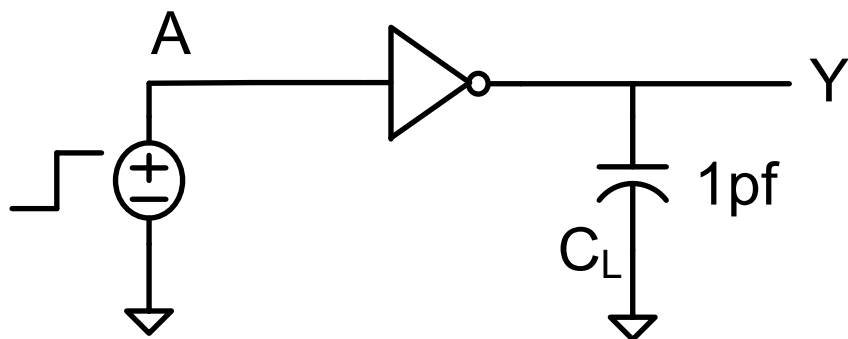

Assume output in low state for a long time and upper switch closes at time $t=0$

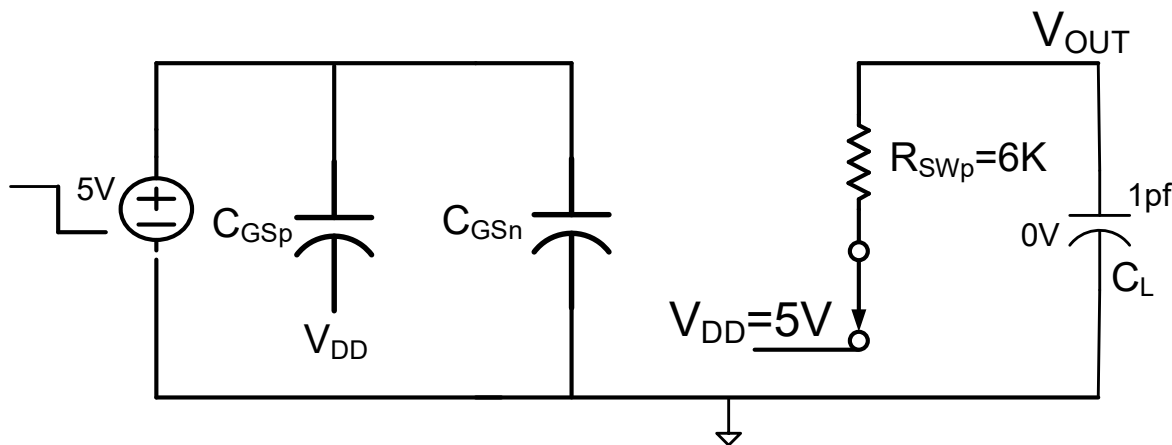

0V is the initial condition on C_L

Example (cont)

With improved model $t_{LH}=?$

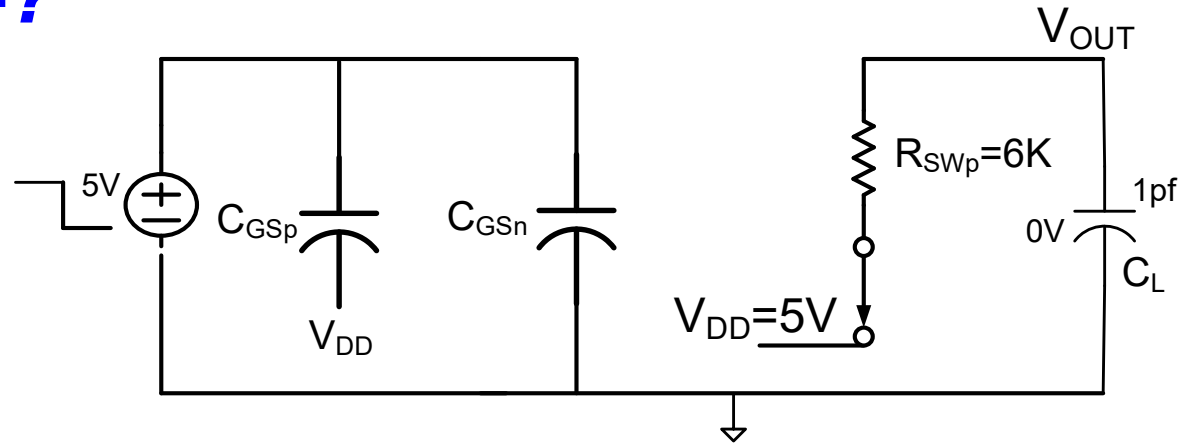

$$y(t) = F + (I - F)e^{-\frac{t}{\tau}}$$

For this circuit, $F=5$, $I=0$ and $\tau = R_{swp} C_L$

Example (cont)

With improved model

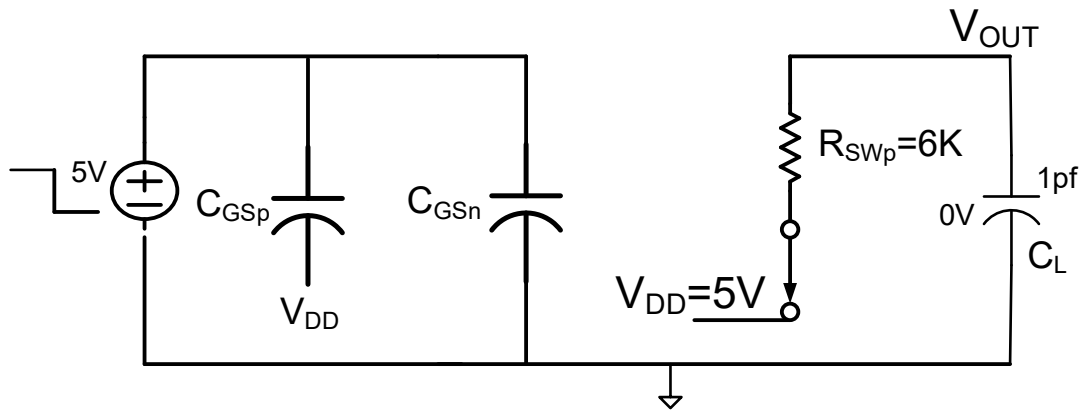

$t_{LH}=?$

$$V_{OUT}(t) = F + (I - F)e^{-\frac{t}{\tau}}$$

$$V_{OUT}(t) = 5\left(1 - e^{-\frac{t}{\tau}}\right)$$

$$\tau = R_{SWp} C_L$$

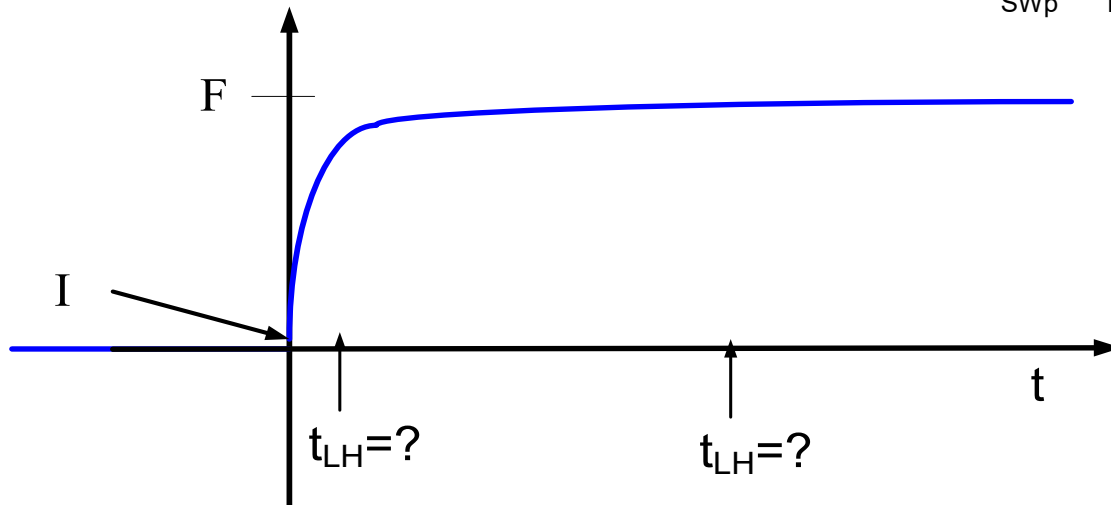

how is t_{LH} defined?

Example (cont)

With improved model

$t_{LH}=?$

Define t_{LH} as shown on figure

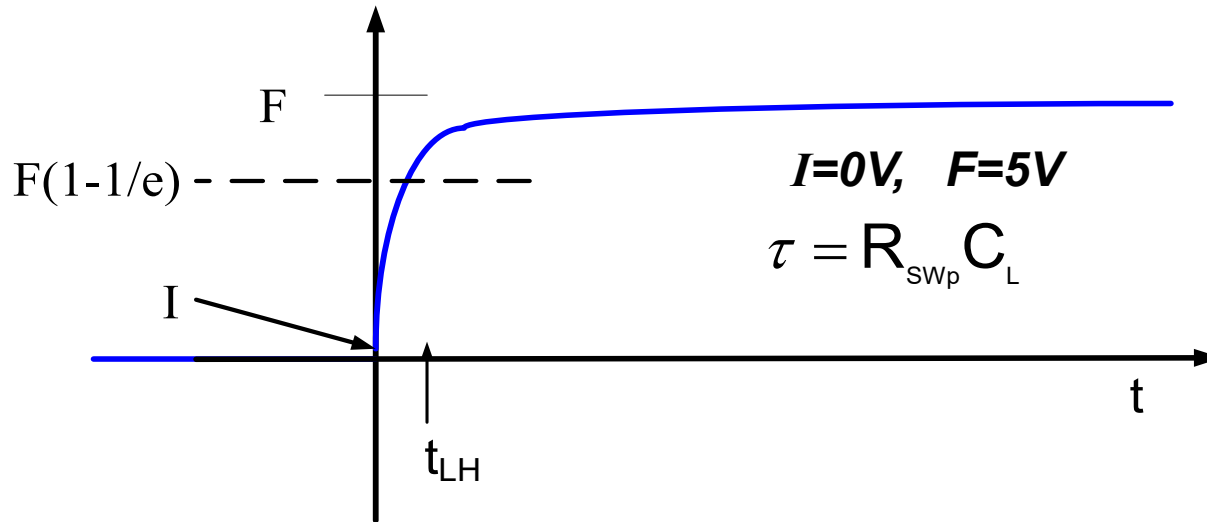
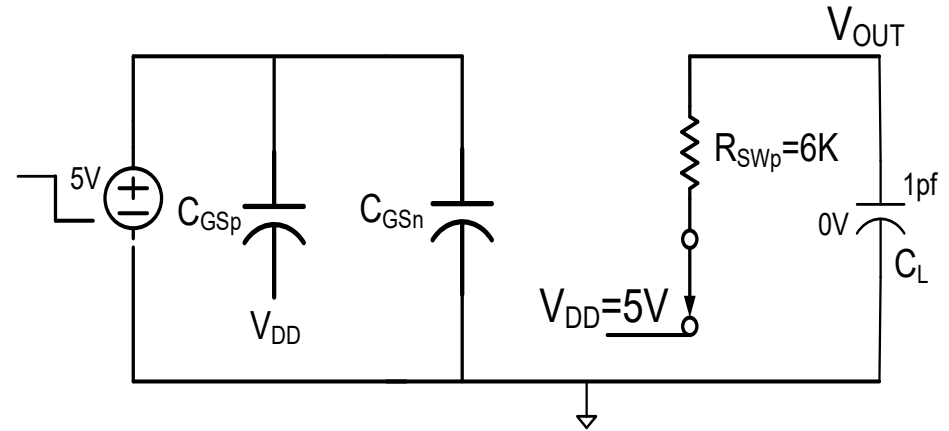

t_{LH} as defined has proven useful for analytically predicting response time of circuits

$$V_{OUT}(t) = F + (I - F)e^{-\frac{t}{\tau}} \quad \longrightarrow \quad F\left(1 - \frac{1}{e}\right) = F + (I - F)e^{-\frac{t_{LH}}{\tau}}$$

Example (cont)

With improved model

$$t_{LH}=?$$

$$F\left(1 - \frac{1}{e}\right) = F + (I - F)e^{-\frac{t_{LH}}{\tau}}$$

$$F\left(1 - \frac{1}{e}\right) = F + (F)e^{-\frac{t_{LH}}{\tau}}$$

$$1 - \frac{1}{e} = 1 + e^{-\frac{t_{LH}}{\tau}}$$

$$t_{LH} = \tau$$



$$t_{LH} = R_{SWp} C_L$$

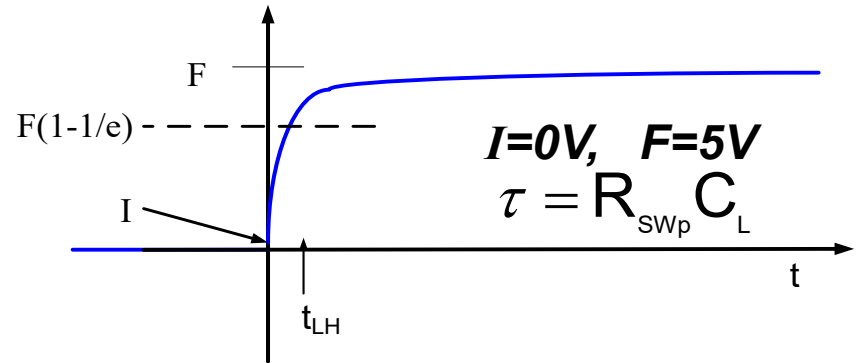

Example (cont)

With improved model

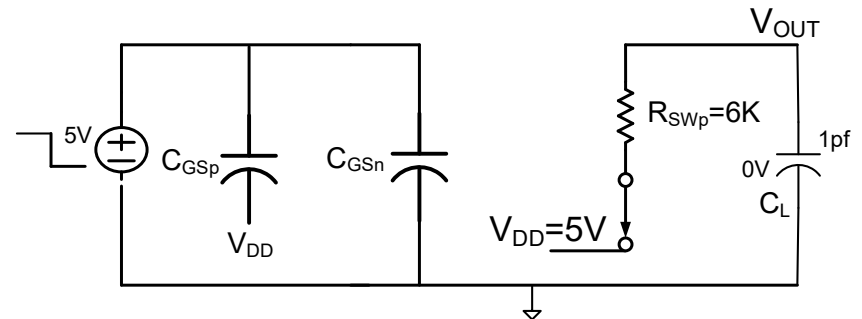
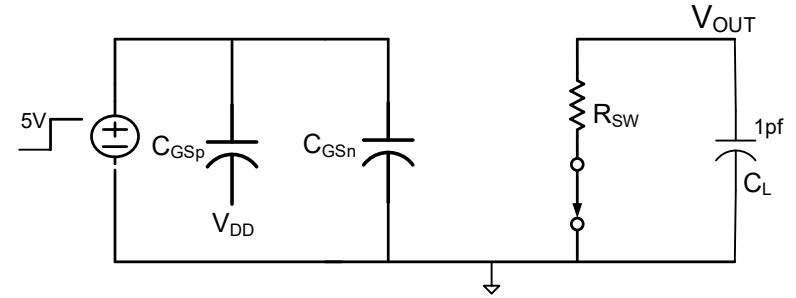

$$t_{HL} \cong R_{SWn} C_L$$

In the ON 0.5u process
 $= 2K \bullet 1pF = 2n \text{ sec}$

$$t_{LH} \cong R_{SWp} C_L$$

$$= 6K \bullet 1pF = 6n \text{ sec}$$

Note this circuit is quite fast !

Note that t_{HL} is much shorter than t_{LH}

Often C_L will be even smaller and the circuit will be much faster !!

Summary: What is the delay of a minimum-sized inverter driving a 1pF load?

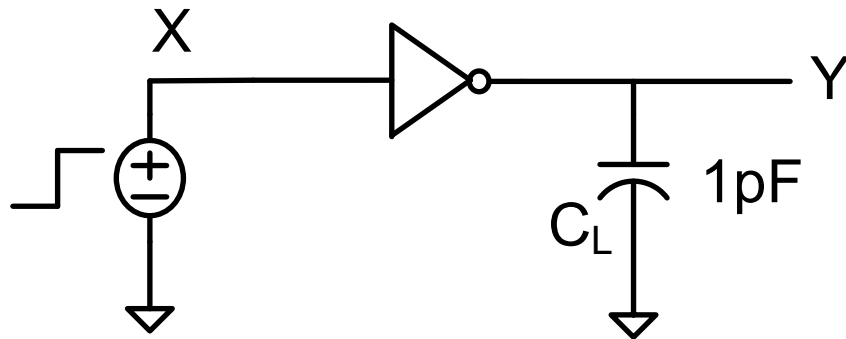

In the ON 0.5 μ process

$$t_{HL} \cong R_{SWn} C_L = 2K \bullet 1pF = 2n \text{ sec}$$

$$t_{LH} \cong R_{SWp} C_L = 6K \bullet 1pF = 6n \text{ sec}$$

Improved switch-level model

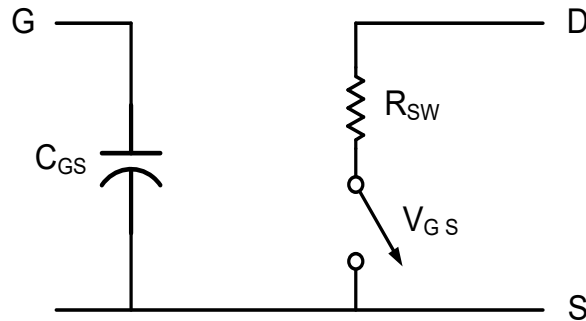
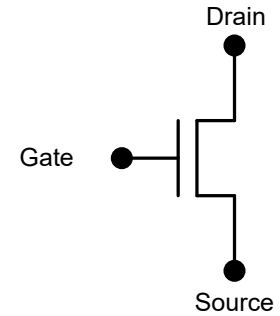

Switch closed for $V_{GS} = \text{large}$

Switch open for $V_{GS} = \text{small}$

- Previous example showed why R_{SW} in the model was important
- But of what use is the C_{GS} which did not enter the previous calculations?

For minimum-sized devices in a 0.5μ process

$$C_{GS} \cong 1.5\text{fF} \quad R_{sw} \cong \left. \begin{array}{l} 2\text{K}\Omega \text{ n-channel} \\ 6\text{K}\Omega \text{ p-channel} \end{array} \right\}$$

One gate often drives one or more other gates !

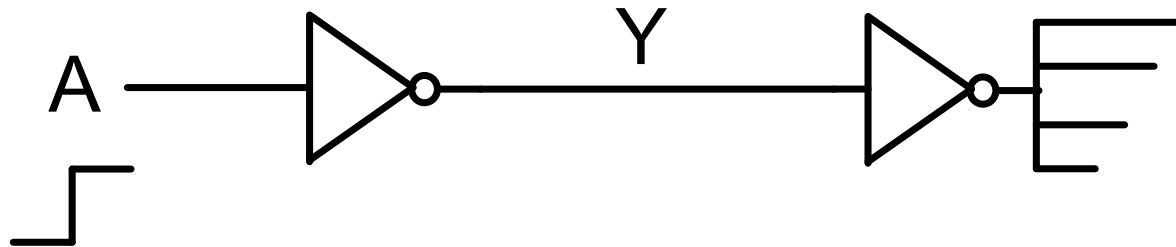

What are t_{HL} and t_{LH} ?

Example: What is the delay of a minimum-sized inverter driving another identical device?

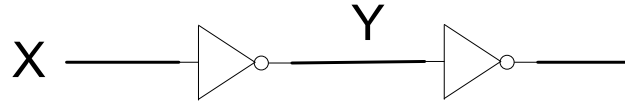

Load on first inverter

C_{GSn} and C_{GSp} both 1.5fF

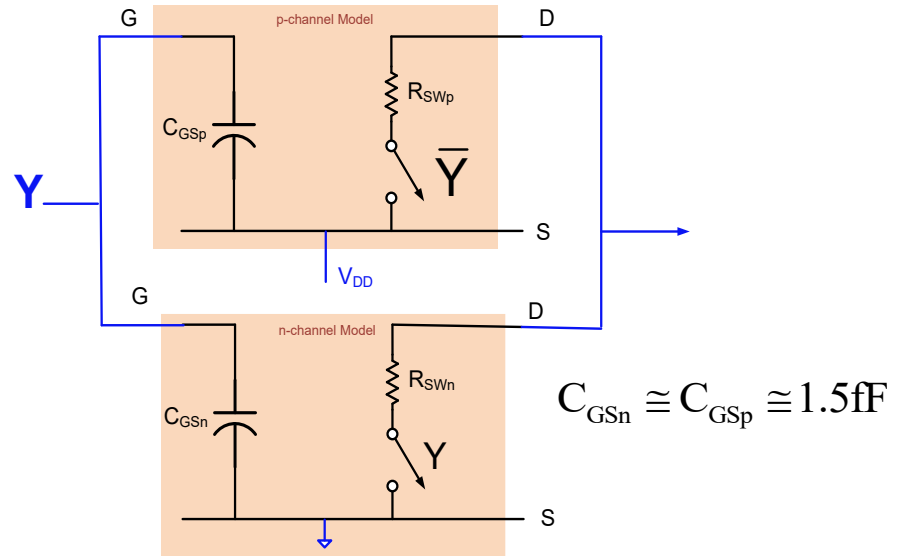

Loading effects same whether C_{GSp} and/or C_{GSn} connected to V_{DD} or GND

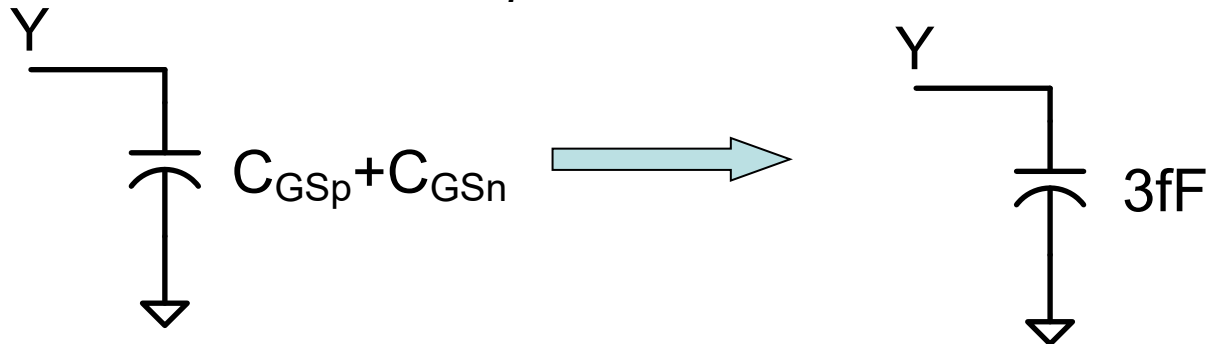

For convenience, will reference both to ground

Is a capacitor of 1.5fF small enough to be neglected?

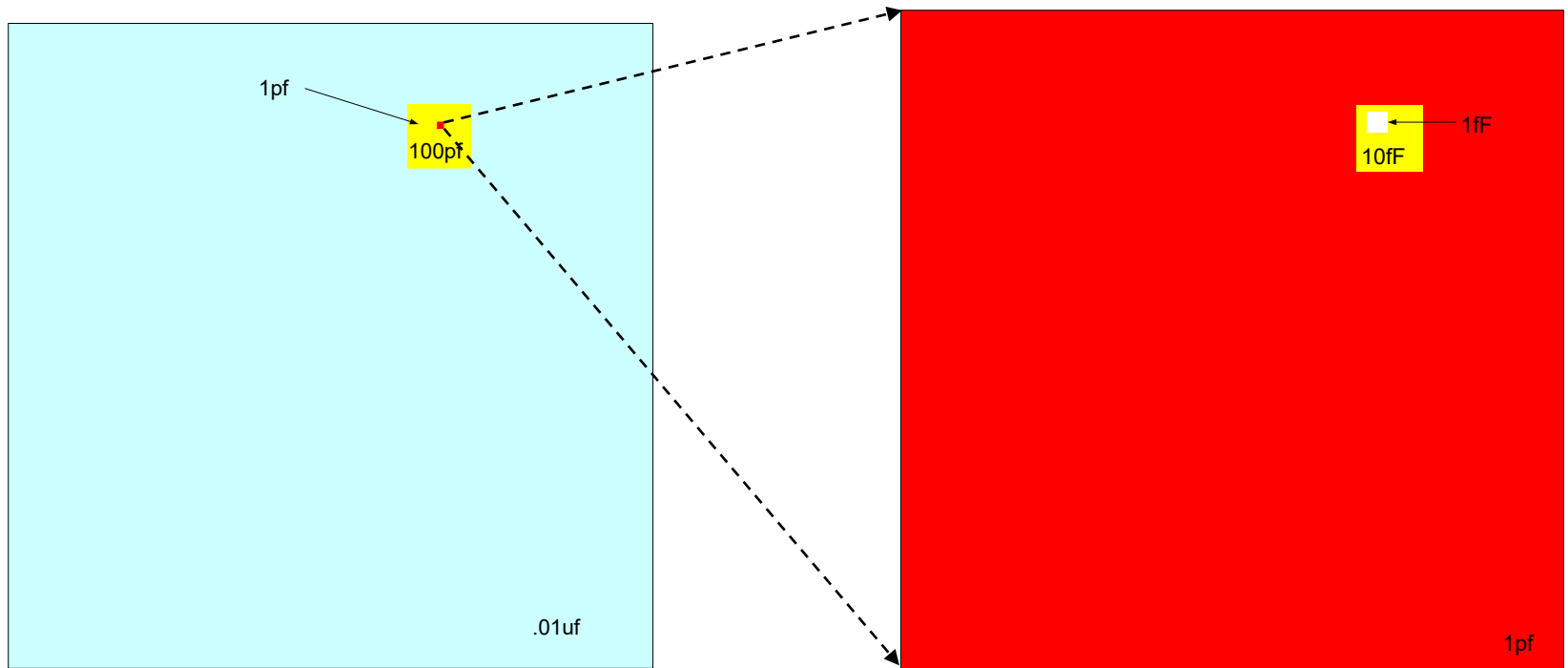

Area allocations shown to relative scale:

- This example will provide insight into the answer of the question

Example: What is the delay of a minimum-sized inverter driving another identical device? Assume $V_{DD}=5V$

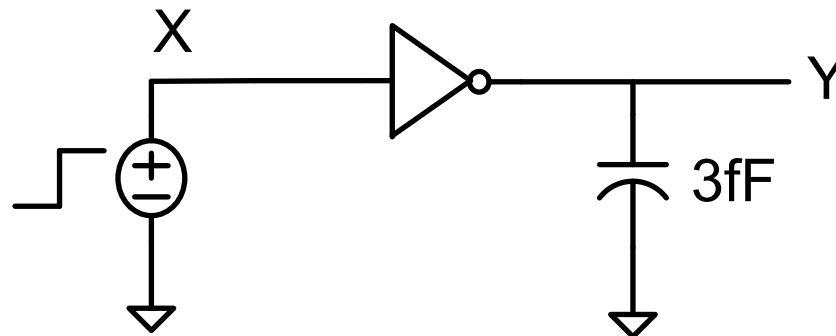
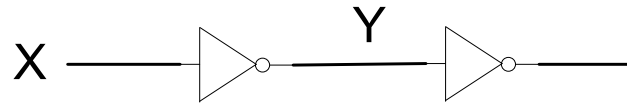

Generalizing the Previous Analysis to Arbitrary Load

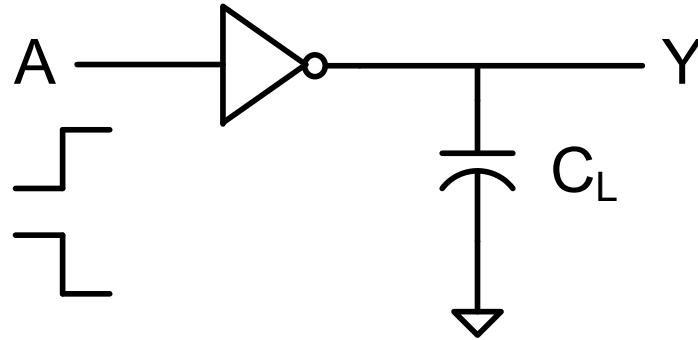

$$t_{HL} \cong R_{SWn} C_L$$

$$t_{LH} \cong R_{SWp} C_L$$

Example: What is the delay of a minimum-sized inverter driving another identical device?

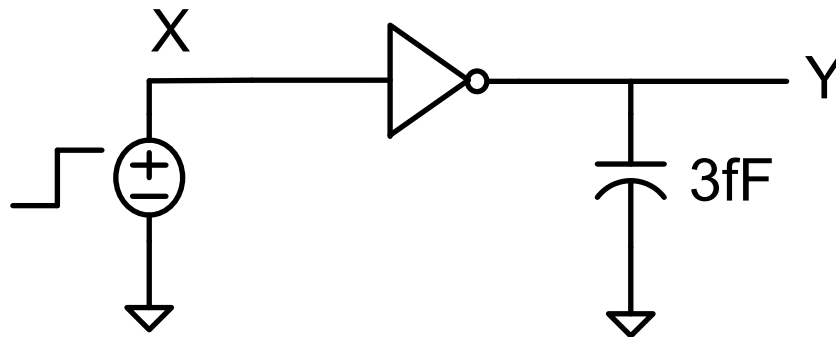
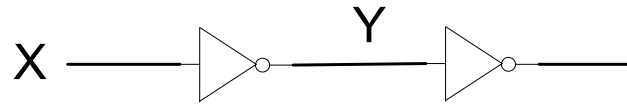

$$t_{HL} \cong R_{SWn} C_L = 2K \bullet 3fF = 6p \text{ sec}$$

$$t_{LH} \cong R_{SWp} C_L = 6K \bullet 3fF = 18p \text{ sec}$$

Do gates really operate this fast?

What would be the maximum clock rate for acceptable operation?

Example: What is the delay of a minimum-sized inverter driving another identical device?

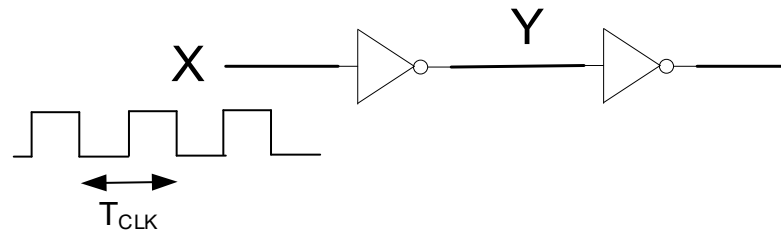

$$t_{HL} \cong R_{SWn} C_L = 6 p \text{ sec}$$

$$t_{LH} \cong R_{SWp} C_L = 18 p \text{ sec}$$

What would be the maximum clock rate for acceptable operation?

$$T_{CLK\text{-min}} = t_{HL} + t_{LH}$$

$$f_{CLK\text{-max}} = \frac{1}{T_{CLK\text{-min}}} = \frac{1}{24 \text{ psec}} = 40 \text{ GHz}$$

And much faster in a finer feature process !!

???????

What would be the implications of allowing for 10 levels of logic and 10 loads (FanOut=10)?

Example: What is the delay of a minimum-sized inverter driving another identical device? SUMMARY

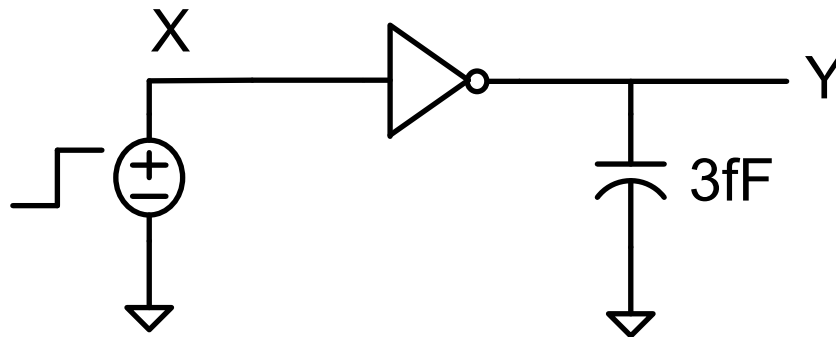
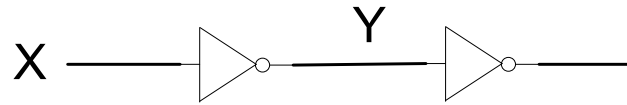

$$t_{HL} \cong R_{SWn} C_L = 2K \bullet 3fF = 6p \text{ sec}$$

$$t_{LH} \cong R_{SWp} C_L = 6K \bullet 3fF = 18p \text{ sec}$$

Note this is very fast but even the small 1.5fF capacitors are not negligible !

Response time of logic gates

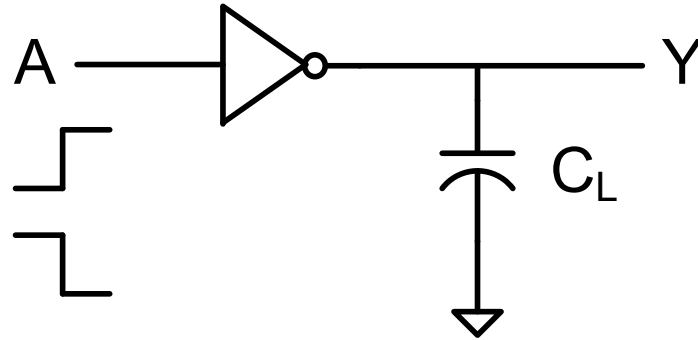

$$t_{HL} \cong R_{SWn} C_L$$

$$t_{LH} \cong R_{SWp} C_L$$

- Logic Circuits can operate very fast
- Extremely small parasitic capacitances play key role in speed of a circuit

Some Observations about Technology and Politics

Technology discussions and laboratory designs in this course will be in an ON 0.5 μ m process

This technology was State of the Art in about 1995 (25 years ago!)

State of the Art today is about 7nm

Technology Evolution:

5 μ m, 3 μ m, 1 μ m, 0.5 μ m, 0.35 μ m, 0.5 μ m, 0.18 μ m , 0.1 μ m, 90nm, 65nm, 45nm, 28nm, 22nm, 14nm, 10nm, 7nm, 5nm

11 generations since the 0.5 μ m process was at the State of the Art

When 0.5 μ m processes were state of the art, most US researchers and most universities were working with the state of the art processes or maybe one generation behind the state of the art

Some Observations about Technology and Politics

Technology Evolution:

5 μ m, 3 μ m, 1 μ m, 0.5 μ m, 0.35 μ m, 0.5 μ m, 0.18 μ m , 0.1 μ m, 90nm, 65nm,
45nm, 28nm, 22nm, 14nm, 10nm, 7nm, 5nm

Students at universities in Asia and Europe often have ready access to technologies in the 14nm to 28nm realm

Are we using obsolete technology in US Universities Today?

Why do we not have ready access to “state of the art” technologies in US Universities?

Will students trained with 25 year old technologies be able to work with state of the art technologies?

Are the larger feature size technologies still used by industry today in the US or abroad?

Some Observations about Technology and Politics

US Government has recognized that investment in the semiconductor industry is critical to regain technical dominance in the field

The US is now in a serious catchup position because except for Intel, US technology is now more than a decade behind foreign competitors

A recent announcement looks promising for the future !

<https://www.washingtonpost.com> › 2021/06/14 › global... ⋮

Senate approved \$52 billion in subsidies for chip manufacturing

This is now a one-time initiative presumably spread over several years

Will this investment close the gap that exists today in semiconductor technology and actually reverse the world order in the semiconductor industry?

Is this a well-recognized mandate?

The U.S. Senate on Tuesday voted 68-32 in favor of legislation i

Some Observations about Technology and Politics

Will this \$52 Billion investment by US Government close the gap that exists today in semiconductor technology or actually reverse the world order in the semiconductor industry?

When Pat Gelsinger, the chief executive of U.S. chip giant Intel, visited Europe this spring to scout potential locations for a new factory, officials rolled out the red carpet. European nations are aiming to use part of a 145 billion euro digital fund — about \$175 billion — to finance chip investments and double [their share of worldwide chip manufacturing](#) by 2030, to 20 percent of the \$540 billion global market.

<https://www.reuters.com> › [technology](#) › [taiwan-minister-s...](#) ⋮

[Taiwan's chip industry set for years of growth: minister | Reuters](#)

Apr 23, 2021 — He said between now and 2025, **Taiwan** companies have planned more than T\$3 trillion (\$107 billion) in **investment** in the **semiconductor** sector, ...

Some Observations about Technology and Politics

Will this \$52 Billion investment by US Government close the gap that exists today in semiconductor technology or actually reverse the world order in the semiconductor industry?

<https://www.industryweek.com> › article › taiwans-tsmc-... ⋮

Taiwan's TSMC Plans \$100 Billion Investment to Meet Demand

Apr 5, 2021 — **Taiwan Semiconductor** Manufacturing Company said Thursday it was planning to **invest** \$100 billion over the next three years to meet soaring ...

South Korea became the latest country to announce a colossal investment in the industry last week. The nation's government said Thursday that **510 trillion South Korean won (\$452 billion)** will be invested in chips by 2030, with the bulk of that coming from private companies in the country. *May 17, 2021*

Samsung Group, South Korea's tech giant, announced on Tuesday that it will invest **\$205 billion (240 trillion won)** in their semiconductor, biopharmaceuticals and telecommunications units over the next three years to enhance its global presence and lead in new industries such as next-generation telecommunication and ... *Aug 24, 2021*

Some Observations about Technology and Politics

Will this \$52 Billion investment by US Government close the gap that exists today in semiconductor technology or actually reverse the world order in the semiconductor industry?

<https://thediplomat.com> › [2020/09](#) › [can-china-become...](#) ⋮

Can China Become the World Leader in Semiconductors?

Sep 25, 2020 — **China** appears on track to reach the **investment** level of \$150 billion in 2020 without having reached either of its stated long-term goals. And ...

Some Observations about Technology and Politics

Will this \$52 Billion investment by US Government close the gap that exists today in semiconductor technology or actually reverse the world order in the semiconductor industry?

Summary of Reported Investments by Some Key Players

Timeframes of investments vary making comparisons sketchy

US Government	\$50 Billion
Intel	\$100 Billion (over 10 years ?)
European Governments	\$175 Billion
Taiwan Government	\$107 Billion
TSMC	\$100 Billion
Korean Government	\$450 Billion
Samsung (included?)	\$205 Billion
China	\$150 Billion (in 2020 alone)

Some Observations about Technology and Politics

There are serious concerns in the US military that we will not be able to maintain state of the art military systems without domestic state of the art semiconductor technology

The lack of access to state of the art semiconductor technologies in most US universities is primarily driven by the lack of commitment by the US government to support these programs and to support the semiconductor industry to the level of support provided in some other countries

Input on re-establishing priority for governmental support of the US semiconductor industry is critical

Many companies around the world are still using 65nm to 0.5 μ m technologies for new designs and will for the foreseeable future

Extremely high volume applications of highly complex systems operating at high speeds drive the state of the art technologies



Stay Safe and Stay Healthy !

End of Lecture 7